



Relion® 620 series

Feeder Protection and Control REF620 Product Guide

Contents

1. Description.....	3	18. Access control.....	22
2. Default configurations.....	3	19. Inputs and outputs.....	22
3. Protection functions.....	9	20. Station communication.....	24
4. Application.....	10	21. Technical data.....	29
5. Supported ABB solutions.....	19	22. Local HMI.....	76
6. Control.....	20	23. Mounting methods.....	76
7. Measurement.....	21	24. Relay case and plug-in unit.....	77
8. Power quality.....	21	25. Selection and ordering data.....	78
9. Fault location.....	21	26. Accessories and ordering data.....	82
10. Disturbance recorder.....	21	27. Tools.....	82
11. Event log.....	22	28. Cyber security.....	83
12. Recorded data.....	22	29. Connection diagrams.....	84
13. Condition monitoring	22	30. Certificates.....	87
14. Trip-circuit supervision.....	22	31. References.....	87
15. Self-supervision.....	22	32. Functions, codes and symbols.....	88
16. Fuse failure supervision.....	22	33. Document revision history.....	95
17. Current circuit supervision.....	22		

Disclaimer

The information in this document is subject to change without notice and should not be construed as a commitment by ABB. ABB assumes no responsibility for any errors that may appear in this document.

© Copyright 2015 ABB.

All rights reserved.

Trademarks

ABB and Relion are registered trademarks of the ABB Group. All other brand or product names mentioned in this document may be trademarks or registered trademarks of their respective holders.

Feeder Protection and Control	1MRS757844 E
REF620	
Product version: 2.0 FP1	Issued: 2015-12-11
	Revision: E

1. Description

REF620 is a dedicated feeder management relay perfectly aligned for the protection, control, measurement and supervision of utility and industrial power distribution systems, including radial, looped and meshed networks, with or without distributed power generation. REF620 can also be used to protect feeders including motors or capacitor banks.

Additionally REF620 offers functionality for interconnection protection used with distributed generation like wind or solar power connection to utility grid. Furthermore REF620 includes functionality for high-impedance based busbar protection.

REF620 is a member of ABB's Relion® protection and control product family and its 620 series. The 620 series relays are characterized by their functional scalability and withdrawable-unit design. The 620 series has been designed to unleash the full potential of the IEC 61850 standard for communication and interoperability of substation automation devices.

The 620 series relays support a range of communication protocols including IEC 61850 with Edition 2 support, process bus according to IEC 61850-9-2 LE, IEC 60870-5-103, Modbus® and DNP3. Profibus DPV1 communication protocol is supported by using the protocol converter SPA-ZC 302.

2. Default configurations

The 620 series relays are configured with default configurations, which can be used as examples of the 620

series engineering with different function blocks. The default configurations are not aimed to be used as real end-user applications. The end-users always need to create their own application configuration with the configuration tool. However, the default configuration can be used as a starting point by modifying it according to the requirements.

REF620 is available in two alternative default configurations: configuration A with traditional current and voltage measurement transducers and configuration B with current and voltage sensors. Default configuration A with measurement transducers has more voltage measurements and I/Os than default configuration B. This gives more possibilities in applications supported by default configuration A. The default configuration can be altered by means of the graphical signal matrix or the graphical application functionality of the Protection and Control IED Manager PCM600. Furthermore, the application configuration functionality of PCM600 supports the creation of multi-layer logic functions using various logical elements, including timers and flip-flops. By combining protection functions with logic function blocks, the relay configuration can be adapted to user-specific application requirements.

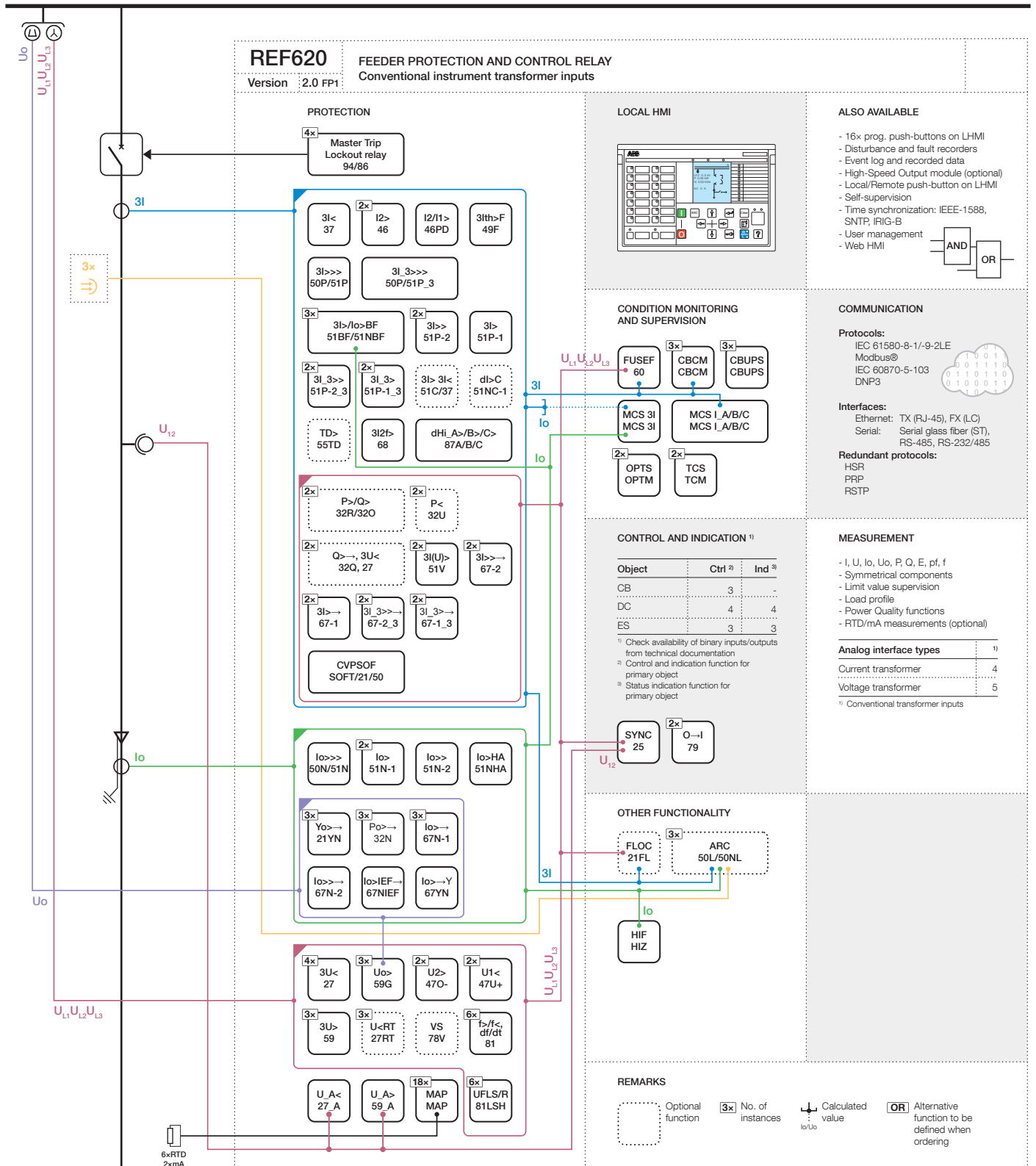

Figure 1. Functionality overview of default configuration with conventional instrument transformer inputs

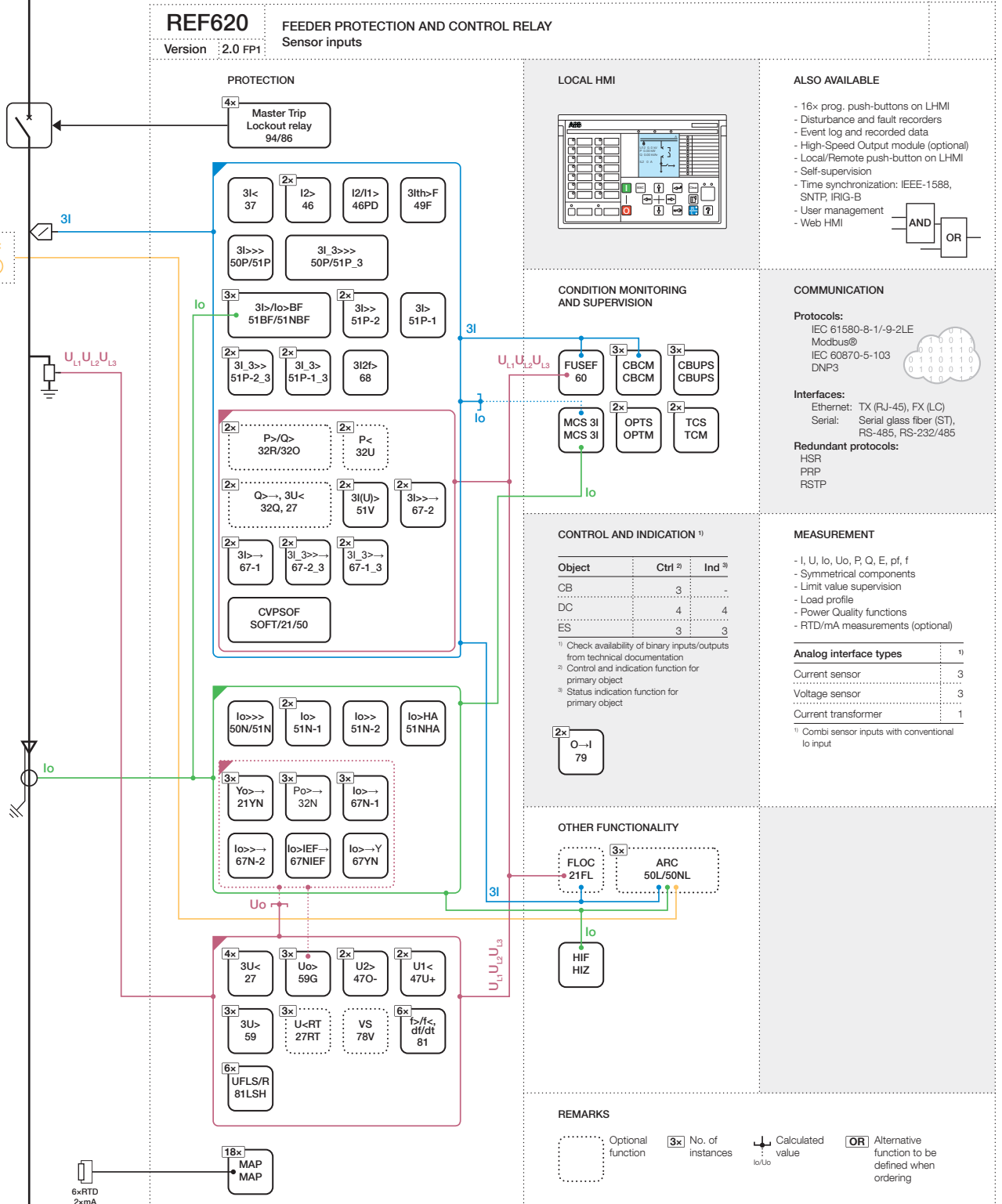

Figure 2. Functionality overview of default configuration with sensor inputs

Table 1. Supported functions

Function	IEC 61850	A (CTs/VTs)	B (Sensors)
Protection			
Three-phase non-directional overcurrent protection, low stage	PHLPTOC	1	1
Three-phase non-directional overcurrent protection, high stage	PHHPTOC	2	2
Three-phase non-directional overcurrent protection, instantaneous stage	PHIPTOC	1	1
Three-phase directional overcurrent protection, low stage	DPHLPDOC	2	2
Three-phase directional overcurrent protection, high stage	DPHHPDOC	2	2
Three-phase voltage-dependent overcurrent protection	PHPVOC	2	2
Non-directional earth-fault protection, low stage	EFLPTOC	2	2
Non-directional earth-fault protection, high stage	EFHPTOC	1	1
Non-directional earth-fault protection, instantaneous stage	EFIPTOC1	1	1
Directional earth-fault protection, low stage	DEFLPDEF	3	3 ¹⁾
Directional earth-fault protection, high stage	DEFHPDEF	1	1 ¹⁾
Admittance-based earth-fault protection	EFPADM	3	3 ¹⁾
Wattmetric-based earth-fault protection	WPWDE	3	3 ¹⁾
Multifrequency admittance-based earth-fault protection	MFADPSDE	1	1 ¹⁾
Transient/intermittent earth-fault protection	INTRPTEF	1	1 ¹⁾
Harmonics-based earth-fault protection	HAEFPTOC	1	1
Negative-sequence overcurrent protection	NSPTOC	2	2
Phase discontinuity protection	PDNSPTOC	1	1
Residual overvoltage protection	ROVPTOV	3	3 ¹⁾
Three-phase undervoltage protection	PHPTUV	4	4
Single-phase undervoltage protection, secondary side	PHAPTUV	1	
Three-phase overvoltage protection	PHPTOV	3	3
Single-phase overvoltage protection, secondary side	PHAPTOV	1	
Positive-sequence undervoltage protection	PSPTUV	2	2
Negative-sequence overvoltage protection	NSPTOV	2	2
Frequency protection	FRPFRQ	6	6
Three-phase thermal protection for feeders, cables and distribution transformers	T1PTTR	1	1
Loss of phase (undercurrent)	PHPTUC	1	1
Circuit breaker failure protection	CCBRBRF	3	3
Three-phase inrush detector	INRPHAR	1	1
Master trip	TRPPTRC	4	4
Arc protection	ARCSARC	(3)	(3)
High-impedance fault detection	PHIZ	1	1
Load-shedding and restoration	LSHDPFRQ	6	6
Multipurpose protection	MAPGAPC	18	18

Table 1. Supported functions, continued

Function	IEC 61850	A (CTs/VTs)	B (Sensors)
Automatic switch-onto-fault logic (SOF)	CVPSOF	1	1
Voltage vector shift protection	VVSPPAM	(1)	(1)
Directional reactive power undervoltage protection	DQPTUV	(2)	(2)
Underpower protection	DUPPDPR	(2)	(2)
Reverse power/directional overpower protection	DOPPDPR	(2)	(2)
Low-voltage ride-through protection	LVRTPTUV	(3)	(3)
High-impedance differential protection for phase A	HIAPDIF	1	
High-impedance differential protection for phase B	HIBPDIF	1	
High-impedance differential protection for phase C	HICPDIF	1	
Circuit breaker uncorresponding position start-up	UPCALH	3	3
Three-independent-phase non-directional overcurrent protection, low stage	PH3LPTOC	2	2
Three-independent-phase non-directional overcurrent protection, high stage	PH3HPTOC	2	2
Three-independent-phase non-directional overcurrent protection, instantaneous stage	PH3IPTOC	1	1
Directional three-independent-phase directional overcurrent protection, low stage	DPH3LPDOC	2	2
Directional three-independent-phase directional overcurrent protection, high stage	DPH3HPDOC	2	2
Three-phase overload protection for shunt capacitor banks	COLPTOC	(1)	
Current unbalance protection for shunt capacitor banks	CUBPTOC	(1)	
Shunt capacitor bank switching resonance protection, current based	SRCPTOC	(1)	
Control			
Circuit-breaker control	CBXCBR	3	3
Disconnecter control	DCXSWI	4	4
Earthing switch control	ESXSWI	3	3
Disconnecter position indication	DCSXSWI	4	4
Earthing switch indication	ESSXSWI	3	3
Autoreclosing	DARREC	2	2
Synchronism and energizing check	SECRSYN	1	(1) ²⁾
Condition monitoring and supervision			
Circuit-breaker condition monitoring	SSCBR	3	3
Trip circuit supervision	TCSSCBR	2	2
Current circuit supervision	CCSPVC	1	1
Current transformer supervision for high-impedance protection scheme for phase A	HZCCASPVC	1	
Current transformer supervision for high-impedance protection scheme for phase B	HZCCBSPVC	1	

Table 1. Supported functions, continued

Function	IEC 61850	A (CTs/VTs)	B (Sensors)
Current transformer supervision for high-impedance protection scheme for phase C	HZCCCSPVC	1	
Fuse failure supervision	SEQSPVC	1	1
Runtime counter for machines and devices	MDSOPT	2	2
Measurement			
Three-phase current measurement	CMMXU	1	1
Sequence current measurement	CSMSQI	1	1
Residual current measurement	RESCMMXU	1	1
Three-phase voltage measurement	VMMXU	1	1
Single-phase voltage measurement	VAMMXU	1	(1) ²⁾
Residual voltage measurement	RESVMMXU	1	
Sequence voltage measurement	VSMSQI	1	1
Three-phase power and energy measurement	PEMMXU	1	1
Load profile record	LDPRLRC	1	1
Frequency measurement	FMMXU	1	1
Fault location			
Fault locator	SCEFRFLO	(1)	(1)
Power quality			
Current total demand distortion	CMHAI	1	1
Voltage total harmonic distortion	VMHAI	1	1
Voltage variation	PHQVVR	1	1
Voltage unbalance	VSQVUB	1	1
Other			
Minimum pulse timer (2 pcs)	TPGAPC	4	4
Minimum pulse timer (2 pcs, second resolution)	TPSGAPC	2	2
Minimum pulse timer (2 pcs, minute resolution)	TPMGAPC	2	2
Pulse timer (8 pcs)	PTGAPC	2	2
Time delay off (8 pcs)	TOFGAPC	4	4
Time delay on (8 pcs)	TONGAPC	4	4
Set-reset (8 pcs)	SRGAPC	4	4
Move (8 pcs)	MVGAPC	4	4
Integer value move	MVI4GAPC	4	4
Analog value scaling	SCA4GAPC	4	4
Generic control point (16 pcs)	SPCGAPC	3	3
Remote generic control points	SPCRGAPC	1	1
Local generic control points	SPCLGAPC	1	1
Generic up-down counters	UDFCNT	12	12

Table 1. Supported functions, continued

Function	IEC 61850	A (CTs/VTs)	B (Sensors)
Programmable buttons (16 buttons)	FKEYGGIO	1	1
Logging functions			
Disturbance recorder	RDRE	1	1
Fault recorder	FLTRFRC	1	1
Sequence event recorder	SER	1	1

1, 2, ... = Number of included instances. The instances of a protection function represent the number of identical protection function blocks available in the standard configuration.

() = optional

1) U_0 is calculated from the measured phase voltages

2) Available only with IEC 61850-9-2 LE

3. Protection functions

The basic configurations available in REF620 consist of a wide range of protection functions making the protection relay suitable for various basic feeder applications. The relay offers directional and non-directional overcurrent and thermal overload protection as well as directional and non-directional earth-fault protection. Admittance-based, harmonics-based or wattmetric-based earth-fault protection can be used in addition to directional earth-fault protection. Furthermore, the relay features sensitive earth-fault protection, phase discontinuity protection, transient/intermittent earth-fault protection, overvoltage and undervoltage protection, residual overvoltage protection, positive-sequence undervoltage protection and negative-sequence overvoltage protection. In addition, the relay offers frequency protection including overfrequency, underfrequency and frequency rate-of-change protection. The relay also incorporates three-pole multi-shot autoreclosing functions for overhead line feeders.

The standard content additionally includes multifrequency admittance-based earth-fault protection providing selective directional earth-fault protection for high-impedance earthed networks. The operation is based on multifrequency neutral admittance measurement utilizing fundamental frequency and harmonic components in U_0 and I_0 .

ABB's continuous investments in research and a close cooperation with customers have resulted in the best earth-fault protection portfolio on the market. These functions are vital with different physical neutral groundings. In REF620, a special filtering algorithm enables dependable and secure fault direction also during intermittent/restriking earth faults. It provides a good combination of reliability and sensitivity of protection with a single function for low ohmic and higher ohmic earth faults and for transient and intermittent or restriking earth faults.

REF620 is also capable of protecting other applications than basic incoming or outgoing feeders. The relay includes high-impedance based busbar protection and measurement circuit supervision functions which enable the feeder relay to be used also for busbar protection. The relay includes an optional function package offering directional active and reactive power protection that enable the protected feeder to include also motors. Additionally, the optional package for capacitor bank protection includes functions for capacitor bank overload, unbalance and resonance protection enabling the protection of single star (wye) connected capacitor banks or double star (wye) connected capacitor banks with isolated or compensated neutral. Furthermore, the relay offers an optional protection package for interconnection protection providing function for low-voltage-ride-through, directional reactive power undervoltage protection (QU) and the voltage vector shift protection. This optional application package together with the relay's basic functionality can be used with distributed power generation like wind power or solar power generation to determine when to stay connected and when to disconnect distributed generation from the utility grid following different utility Grid Codes.

Enhanced with optional hardware and software, the relay also features three light detection point-to-point lens sensors for arc fault protection of the circuit breaker, busbar and cable compartment of metal-enclosed indoor switchgear.

The arc-fault protection sensor interface is available on the optional communication module. Fast tripping increases staff safety and security and limits material damage in an arc fault situation. A binary input and output module can be selected as an option - having three high speed binary outputs (HSO) it further decreases the total operate time with typically 4...6 ms compared to the normal power outputs.

REF620

Product version: 2.0 FP1

4. Application

REF620 provides feeder overcurrent and earth-fault protection for utility and industry distribution networks. The relay fits both isolated neutral networks and networks with resistance- or impedance-earthed neutrals. Furthermore, based on its advanced interstation communication facilities, the relay can also be applied for protecting ring type and meshed distribution networks as well as radial networks.

REF620 can be used with either single- or double-busbar configurations with one or two breakers, and with numerous switching device configurations. It supports a substantial number of both manually and motor-operated disconnectors and earthing switches, and it is capable of running large configurations. The number of controllable devices depends on the number of inputs and outputs left free from other application needs. The number of available I/Os can be increased with the RIO600 Remote I/O device.

The relay offers extensive possibilities to tailor the configurations to application requirements. The tool suite for all Relion relays is Protection and Control IED Manager PCM600, which contains all the necessary tools for configuring the device, including functionality, parameterization, the HMI and communication.

REF620 is an ideal protection and control relay for more advanced feeder schemes. To further improve the arc protection and to minimize the effects of an arc fault, the 620 series relays ordered with the arc protection option can be equipped with an I/O card featuring high-speed outputs operating in one millisecond.

The following figures demonstrate different application examples using relay's basic configuration. The configurations are modified by engineering functionality according to different application needs.

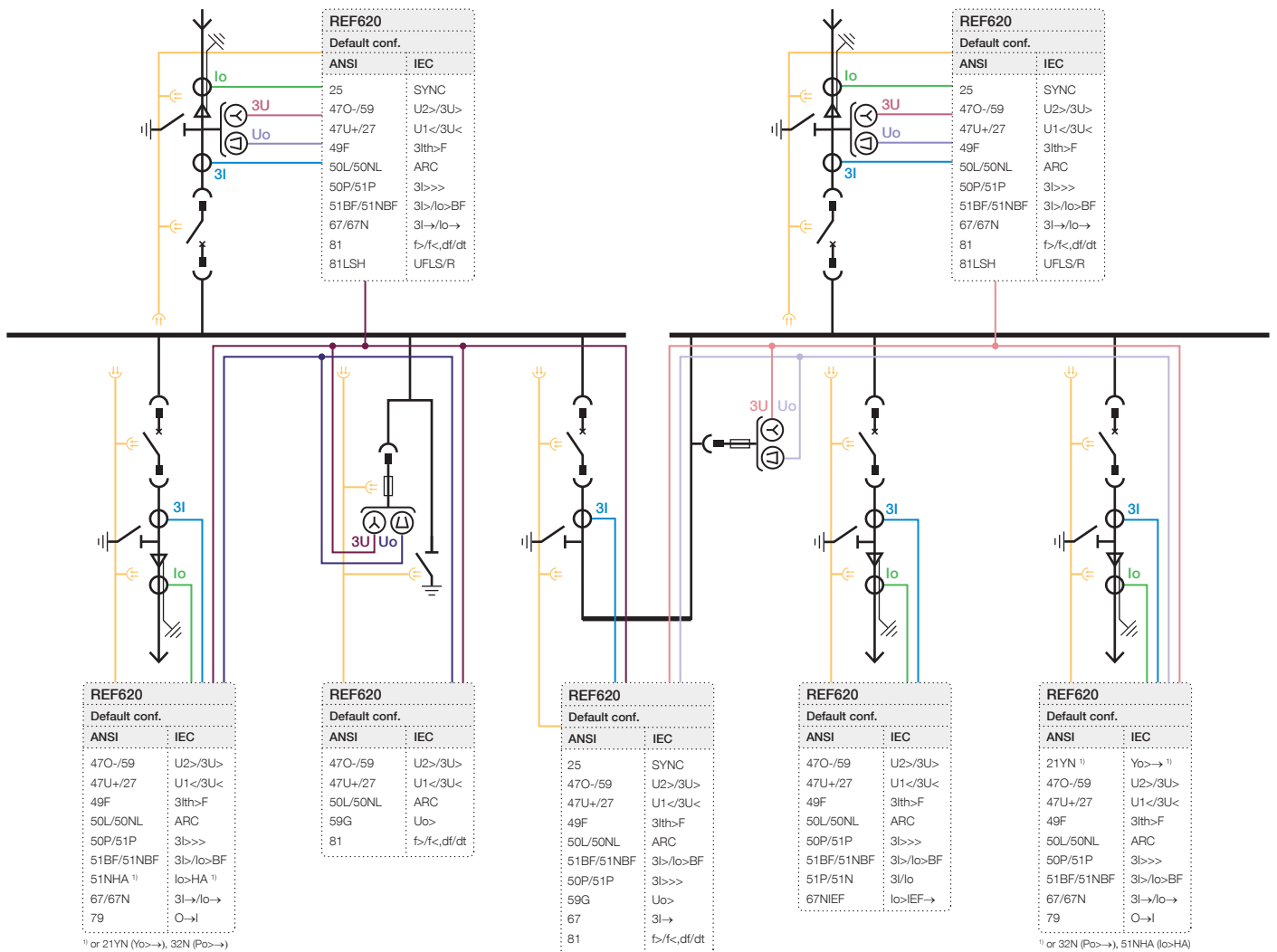

Figure 3. Single busbar AIS 2 section switchgear with conventional instrument transformers

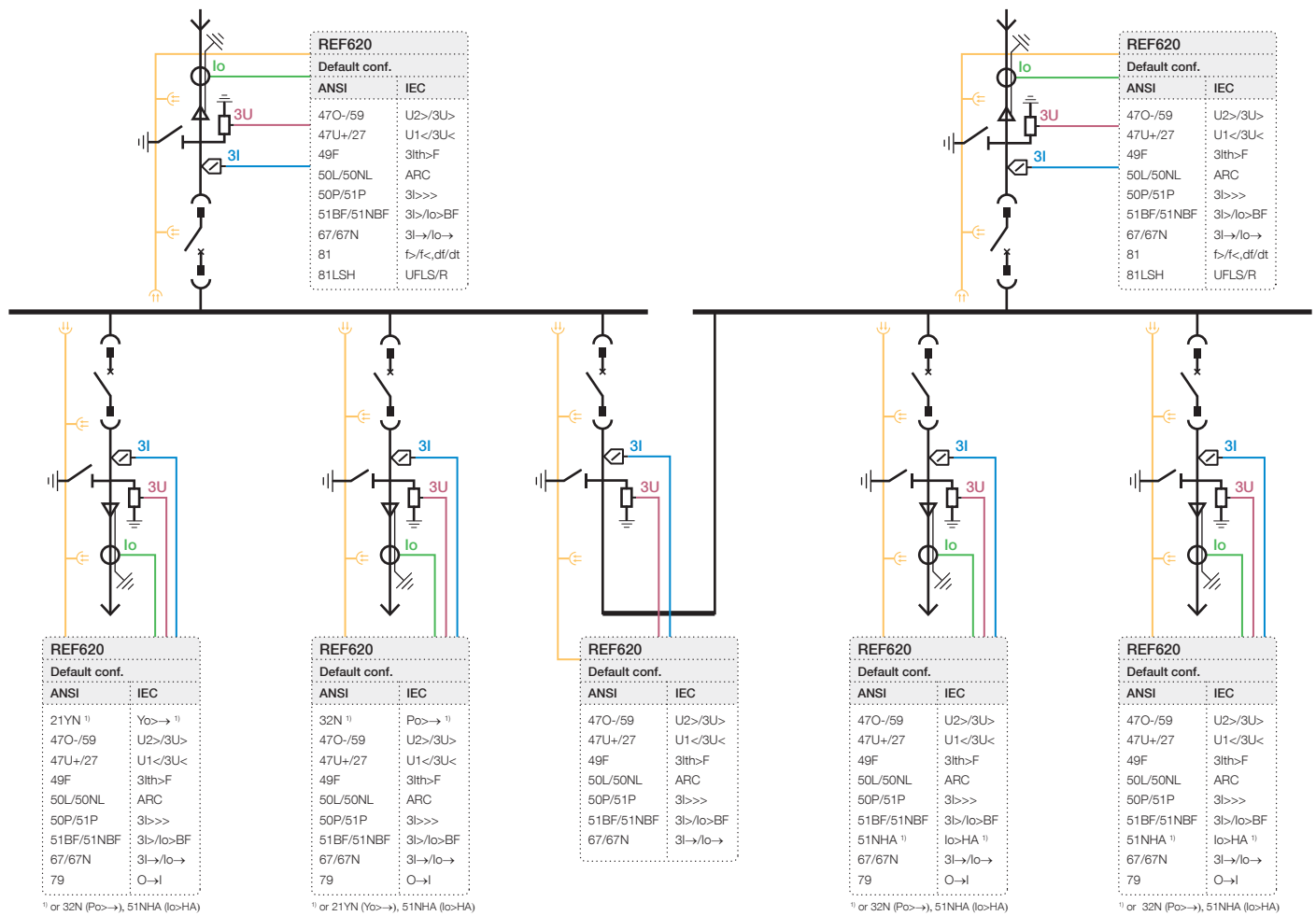

Figure 4. Single busbar AIS switchgear 2 section with sensors

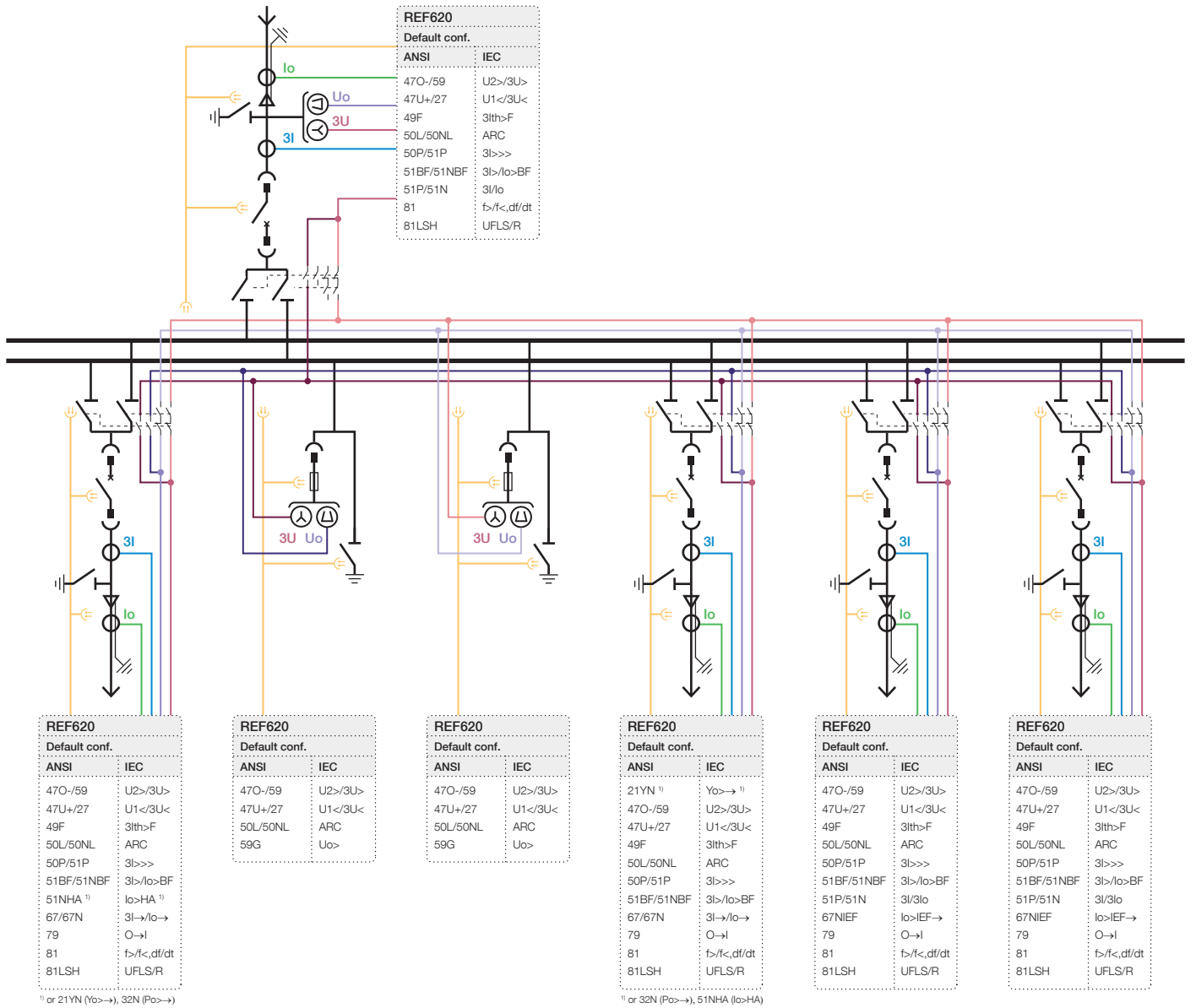

Figure 5. DBB AIS system with one incomer only (with some arrangements simplified)

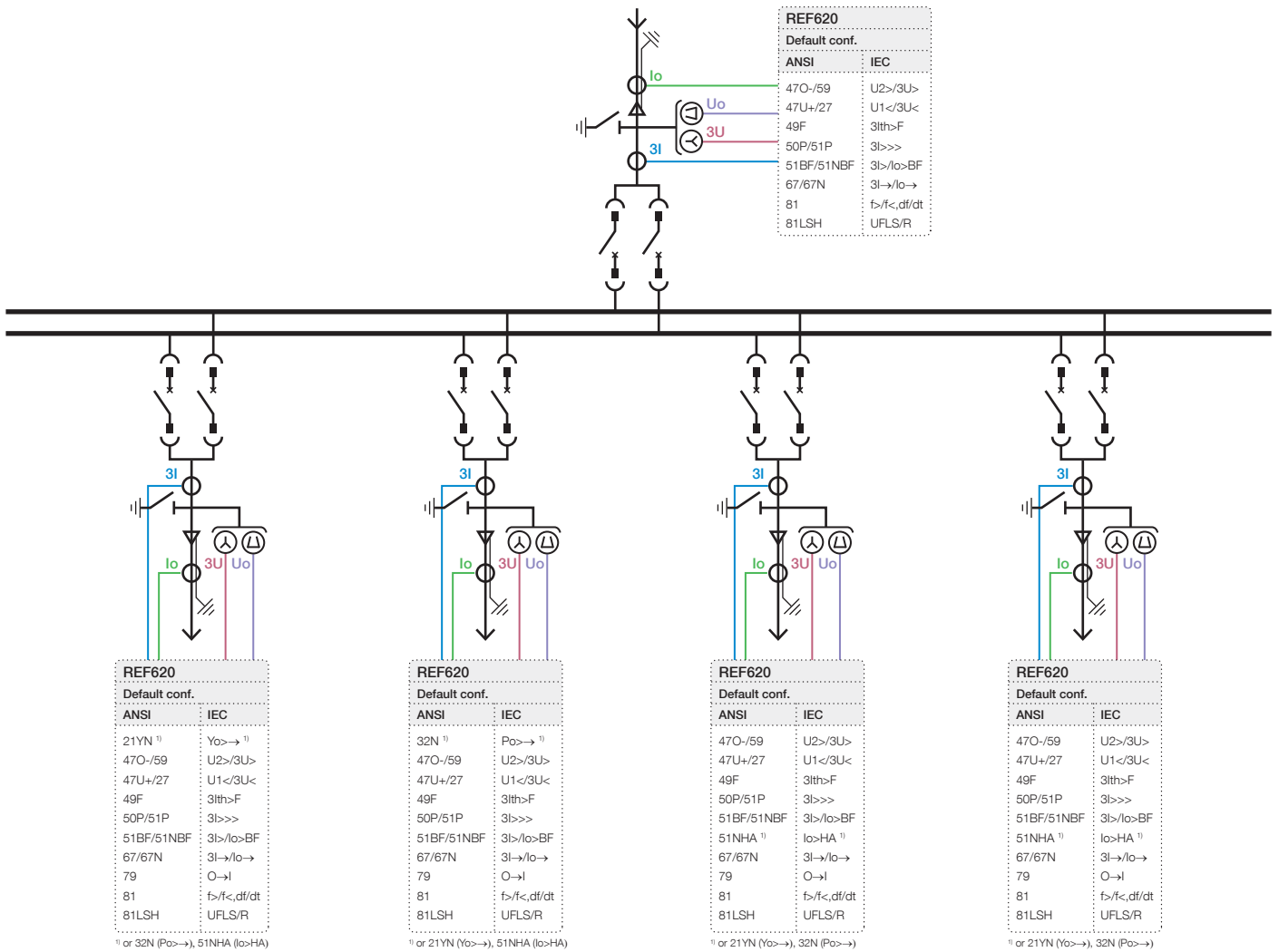

Figure 6. Back-to-back arrangement of AIS switchgear (two single-busbar panels with back walls facing each other), with two circuit breakers and a higher number of disconnectors available; A type of DBB system

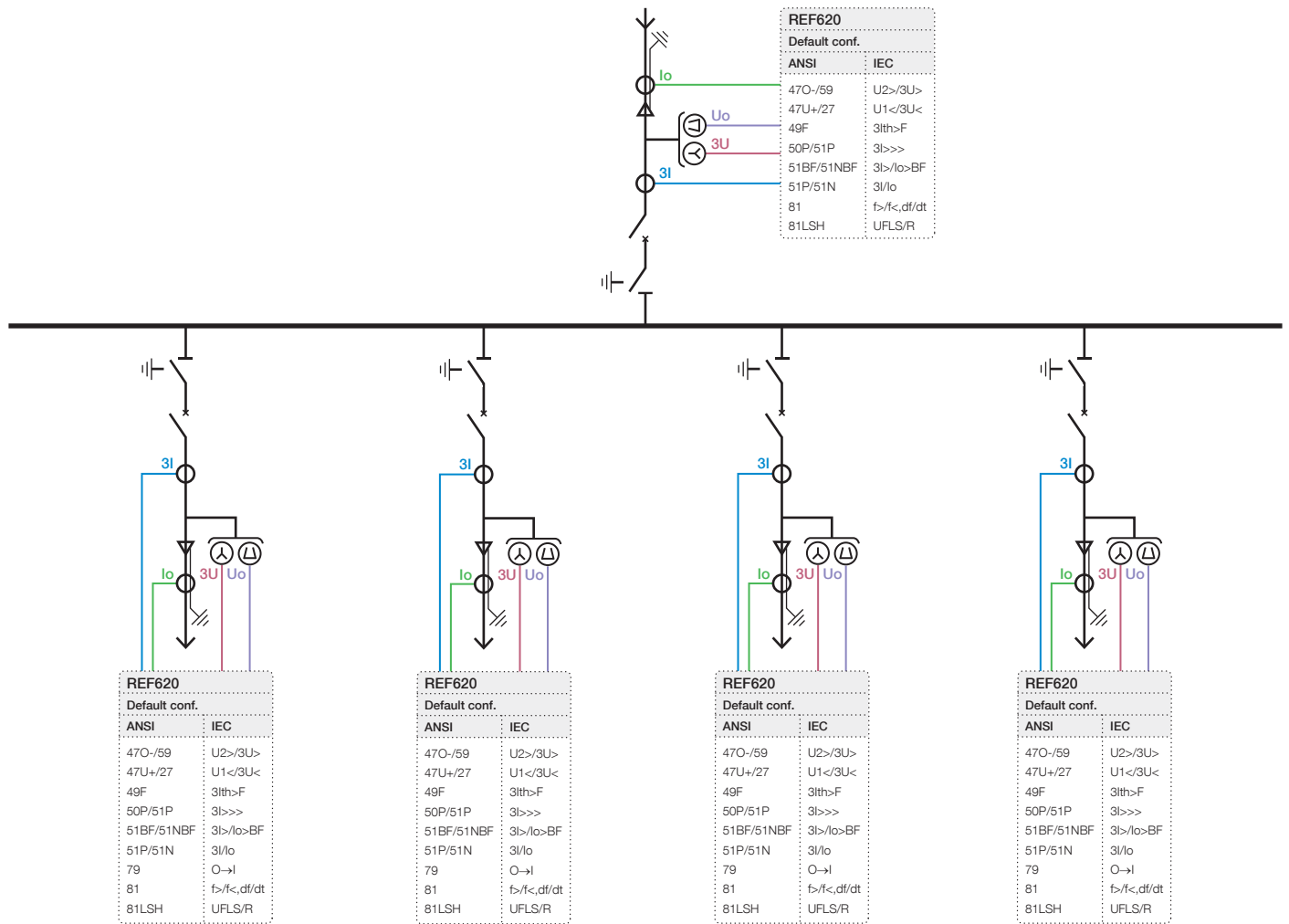

Figure 7. SBB GIS switchgear with the possibility to control the three-position disconnector switch

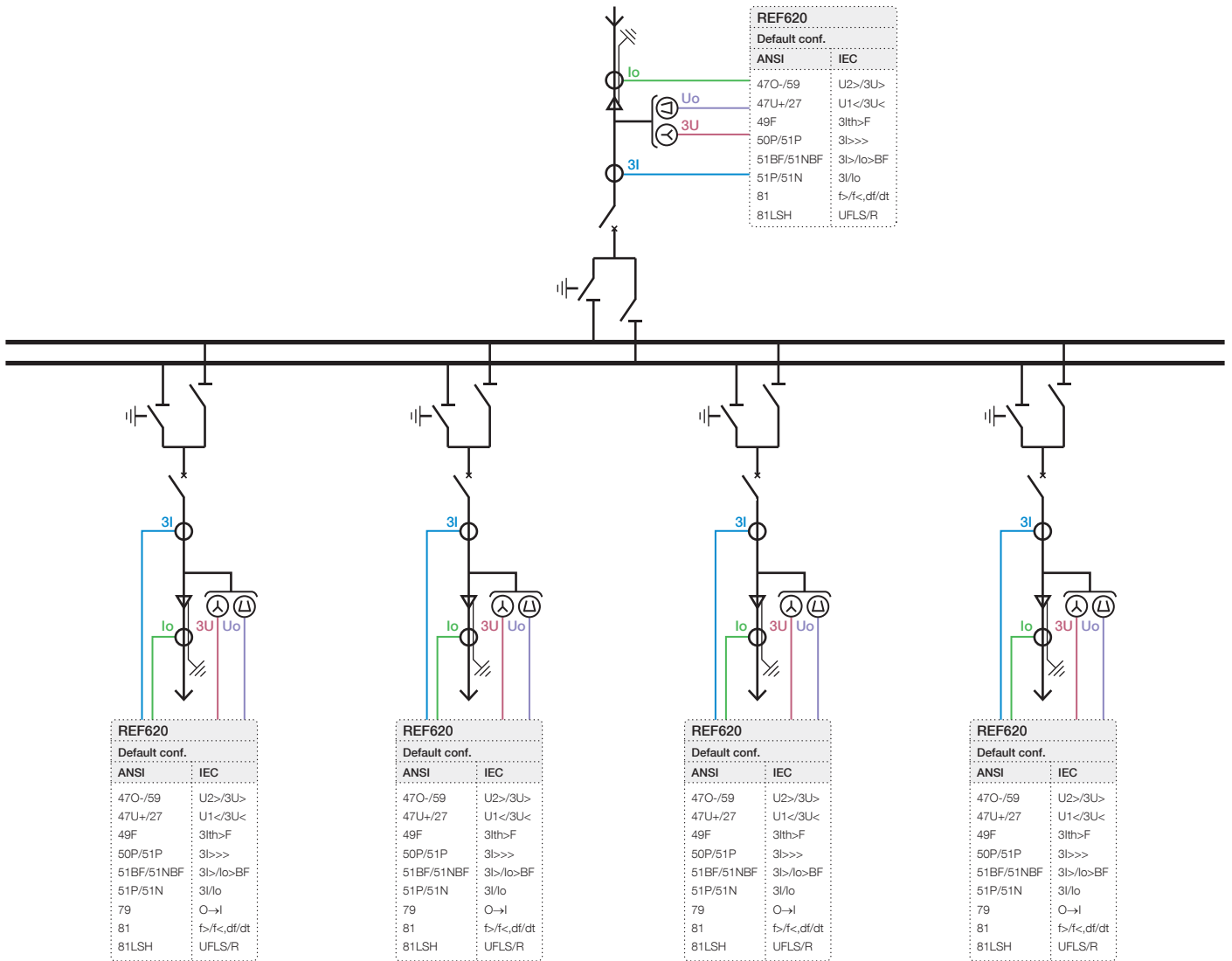

Figure 8. DBB GIS switchgear with the possibility to control the three-position disconnect switch

The following figures demonstrate the application function packages included in the relay. These packages offer new possibilities for several additional applications. The relay's basic functionality includes high-impedance based busbar differential protection functions. Thus, the relay can be engineered for busbar differential protection and by utilizing several relays, multizone differential protection schemes can also be created. The relay includes an optional protection

package for capacitor bank protection and an optional protection package for interconnection protection for distributed power generation, for example, wind power. Furthermore, the relay includes an option for power protection. This package enhances the feeder relay capabilities to protect feeders including motors and includes also basic functionality to protect solar power generation connection to utility grid.

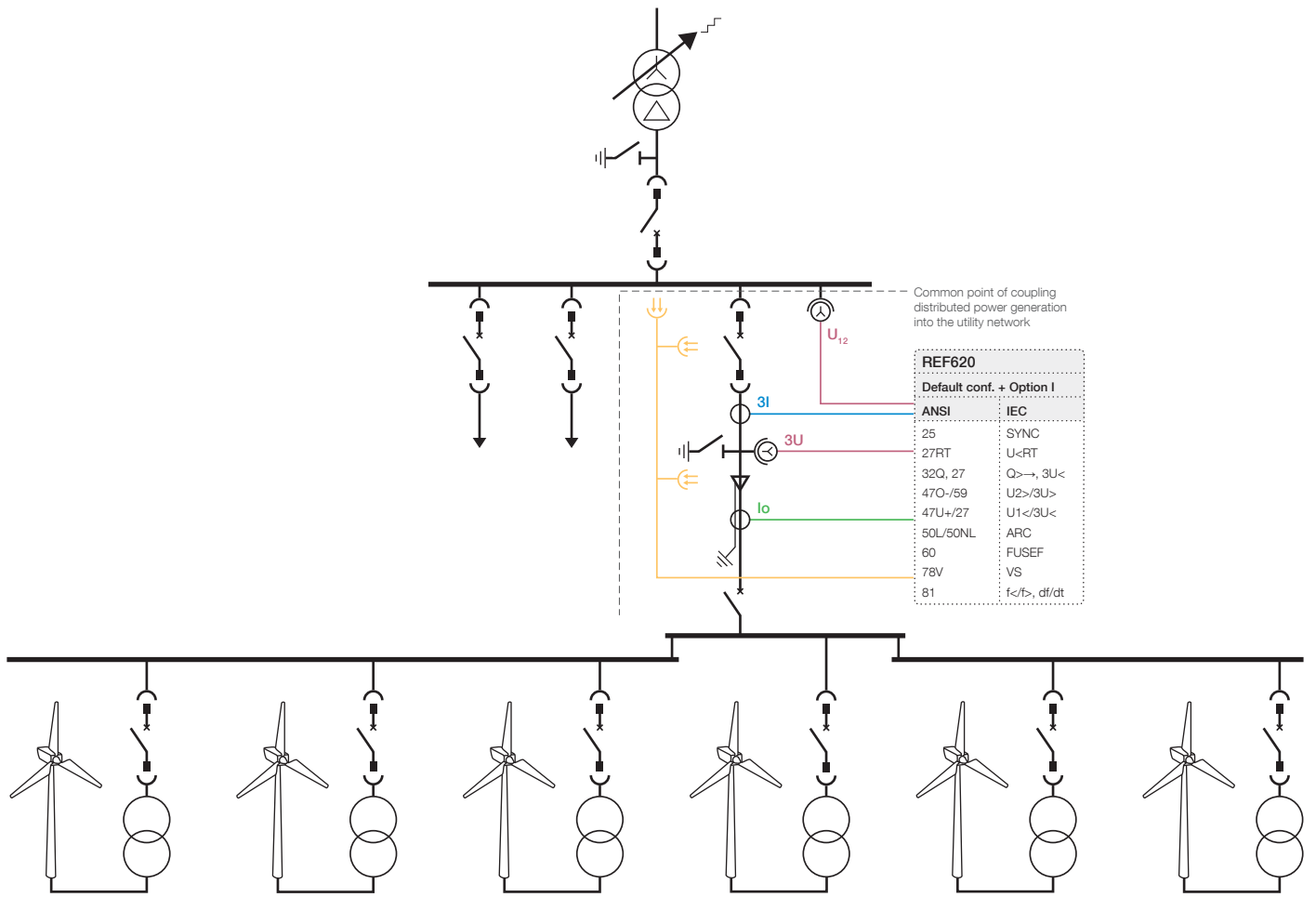

Figure 9. Application example of wind power plant as distributed power generation coupled into the utility network

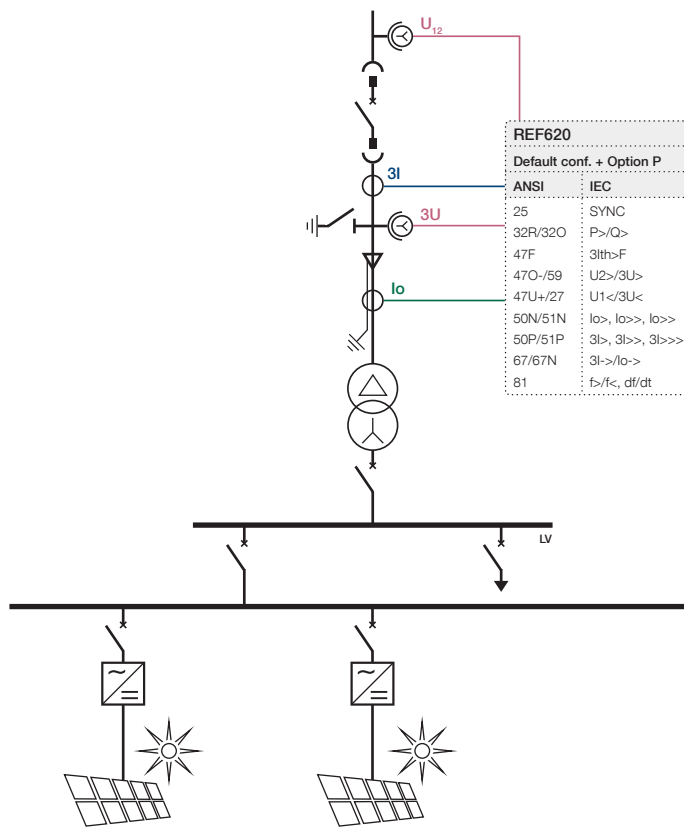

Figure 10. Application example of solar power plant as distributed power generation coupled into the utility network

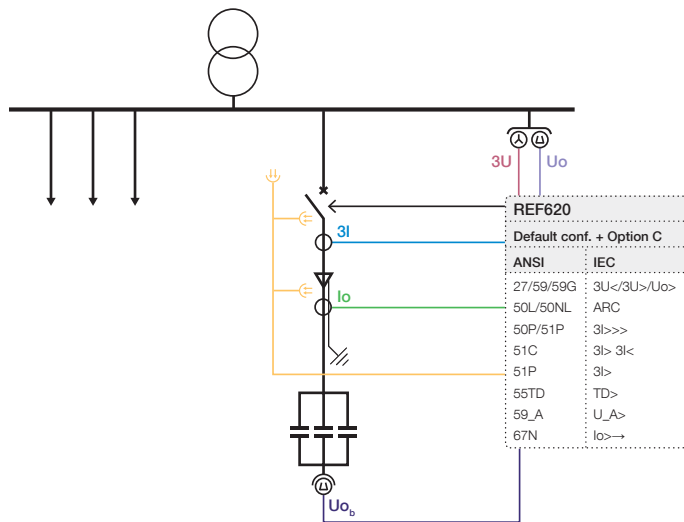

Figure 11. Protection of a single star connected capacitor bank

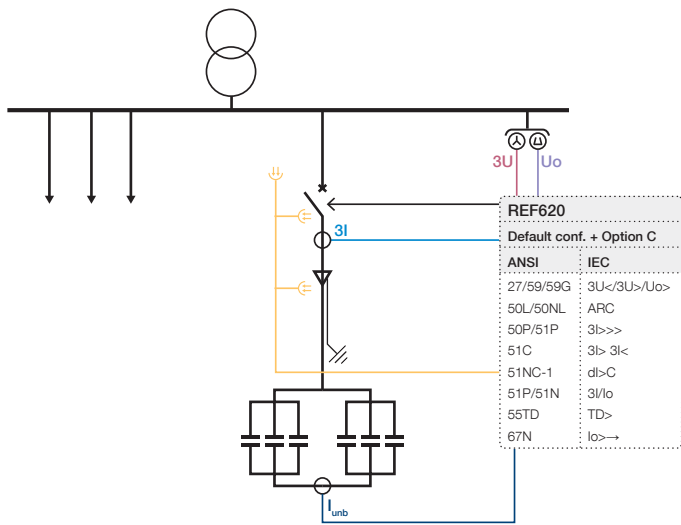

Figure 12. Protection of a double star connected capacitor bank in a distribution network with a compensated or isolated neutral

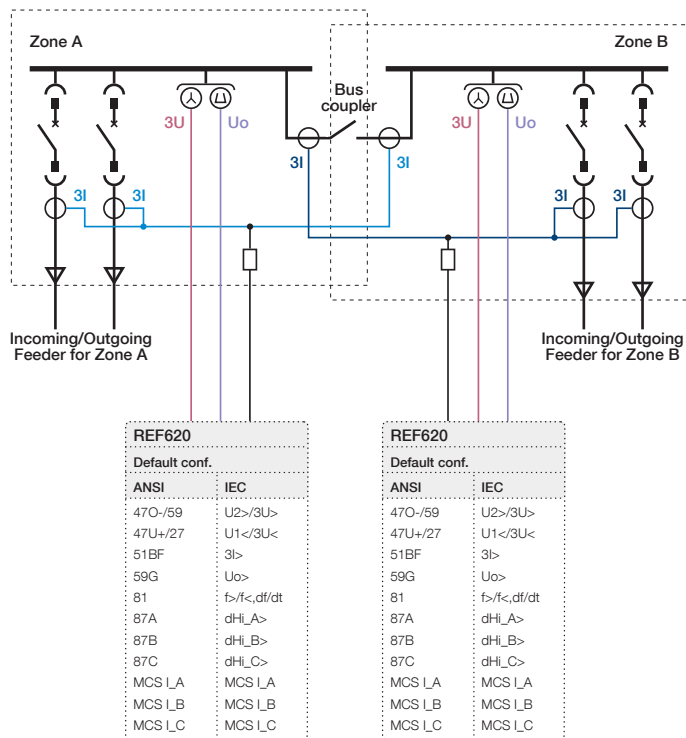

Figure 13. Application example of busbar differential protection covering two zones

5. Supported ABB solutions

ABB's 620 series protection and control relays together with the Substation Management Unit COM600 constitute a genuine IEC 61850 solution for reliable power distribution in utility and industrial power systems. To facilitate and streamline the system engineering, ABB's relays are supplied with connectivity packages. The connectivity packages include a compilation of software and relay-specific information, including single-line diagram templates and a full relay data model. The data model also includes event and parameter lists. With the connectivity packages, the relays can be readily configured using PCM600 and integrated with the Substation Management Unit COM600 or the network control and management system MicroSCADA Pro.

The 620 series relays offer native support for IEC 61850 Edition 2 also including binary and analog horizontal GOOSE messaging. In addition, process bus with the sending of sampled values of analog currents and voltages and the receiving of sampled values of voltages is supported. Compared to traditional hard-wired, inter-device signaling, peer-to-peer communication over a switched Ethernet LAN offers an advanced and versatile platform for power system protection. Among the distinctive features of the protection system approach, enabled by the full implementation of the IEC 61850 substation automation standard, are fast communication capability, continuous supervision of the integrity of the protection and communication system, and an inherent flexibility regarding reconfiguration and upgrades. This protection relay series is able to optimally utilize interoperability provided by the IEC 61850 Edition 2 features.

At substation level, COM600 uses the data content of the bay-level devices to enhance substation level functionality. COM600 features a Web browser-based HMI, which provides a customizable graphical display for visualizing single-line mimic diagrams for switchgear bay solutions. The Web HMI of COM600 also provides an overview of the whole substation, including relay-specific single-line diagrams, which makes information easily accessible. Substation devices and processes can also be remotely accessed through the Web HMI, which improves personnel safety.

In addition, COM600 can be used as a local data warehouse for the substation's technical documentation and for the network data collected by the devices. The collected network data facilitates extensive reporting and analyzing of network fault situations, by using the data historian and event handling features of COM600. The history data can be used for accurate monitoring of process and equipment performance, using calculations based on both real-time and history values. A better understanding of the process dynamics is achieved by combining time-based process measurements with production and maintenance events.

COM600 can also function as a gateway and provide seamless connectivity between the substation devices and network-level control and management systems, such as MicroSCADA Pro and System 800xA.

Table 2. Supported ABB solutions

Product	Version
Substation Management Unit COM600	4.0 SP1 or later
	4.1 or later (Edition 2)
MicroSCADA Pro SYS 600	9.3 FP2 or later
	9.4 or later (Edition 2)
System 800xA	5.1 or later

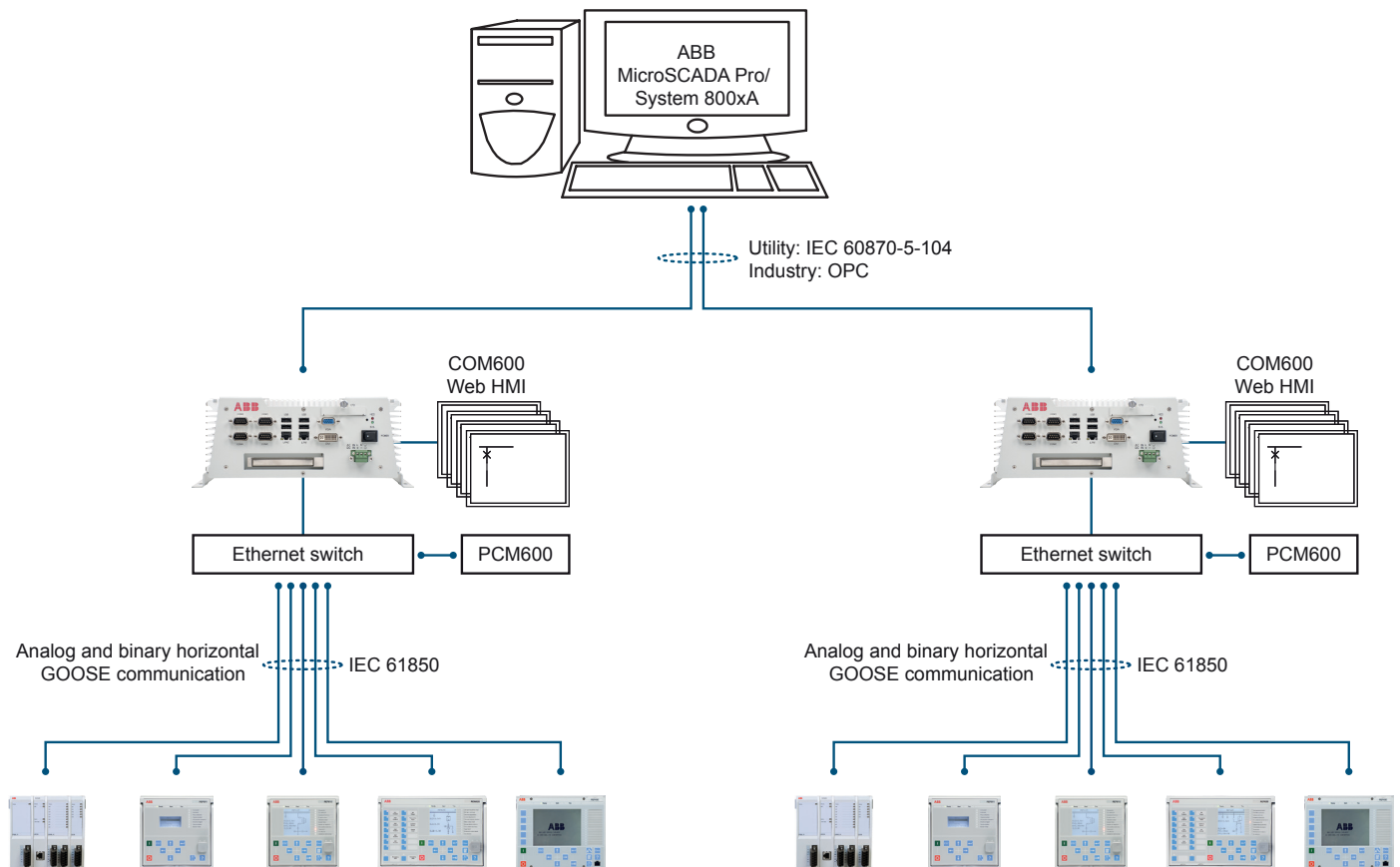

Figure 14. ABB power system example using Relion relays, Substation Management Unit COM600 and MicroSCADA Pro/System 800xA

6. Control

REF620 integrates functionality for the control of circuit breakers, disconnectors and earthing switches via the front panel HMI or by means of remote controls. The relay includes three circuit breaker control blocks. In addition to the circuit breaker control, the relay features four disconnector control blocks intended for the motor-operated control of disconnectors or circuit breaker truck. Furthermore, the relay offers three control blocks intended for the motor-operated control of earthing switch. On top of that, the relay includes additional four disconnector position indication blocks and three earthing switch position indication blocks usable with manually-only controlled disconnectors and earthing switches.

Two physical binary inputs and two physical binary outputs are needed in the relay for each controllable primary device taken into use. Depending on the chosen hardware configuration of the relay, the number of binary inputs and binary outputs varies. In case the amount of available binary inputs or outputs of the chosen hardware configuration is not sufficient, connecting an external input or output module, for example RIO600, to the relay can extend binary inputs and outputs utilizable in the relay

configuration. The binary inputs and outputs of the external I/O module can be used for the less time-critical binary signals of the application. The integration enables releasing of some initially reserved binary inputs and outputs of the relay.

The suitability of the binary outputs of the relay which have been selected for the controlling of primary devices should be carefully verified, for example, the make and carry as well as the breaking capacity. In case the requirements for the control circuit of the primary device are not met, the use of external auxiliary relays should be considered.

The graphical LCD of the relay's HMI includes a single-line diagram (SLD) with position indication for the relevant primary devices. Interlocking schemes required by the application are configured using the Signal Matrix or the Application Configuration tools in PCM600.

Default configuration A incorporates a synchrocheck function to ensure that the voltage, phase angle and frequency on either side of an open circuit breaker satisfy the conditions for a safe interconnection of two networks. Synchrocheck function can also be used with default configuration B when 9-2 process bus

is used. Compared to default configuration A, there are less physical voltage measurements available and thus the voltage measurements from the other side of the breaker have to be read through the 9-2 process bus. An autoreclosing function attempts to restore the power by reclosing the breaker with one to five programmable autoreclosing shots of desired type and duration. The function can be used with every circuit breaker that has the ability for a reclosing sequence. A load-shedding function is capable of performing load shedding based on underfrequency and the rate of change of the frequency.

7. Measurement

The relay continuously measures the phase currents and the neutral current. Furthermore, the relay measures the phase voltages and the residual voltage. In addition, the relay calculates the symmetrical components of the currents and voltages, the system frequency, the active and reactive power, the power factor, the active and reactive energy values as well as the demand value of current and power over a user-selectable preset time frame. Calculated values are also obtained from the protections and condition monitoring functions of the relay.

The values measured can be accessed locally via the user interface on the relay's front panel or remotely via the communication interface of the relay. The values can also be accessed locally or remotely using the Web browser-based user interface.

The relay is provided with a load profile recorder. The load profile feature stores the historical load data captured at a periodical time interval (demand interval). The records are in COMTRADE format.

8. Power quality

In the EN standards, power quality is defined through the characteristics of the supply voltage. Transients, short-duration and long-duration voltage variations and unbalance and waveform distortions are the key characteristics describing power quality. The distortion monitoring functions are used for monitoring the current total demand distortion and the voltage total harmonic distortion.

Power quality monitoring is an essential service that utilities can provide for their industrial and key customers. A monitoring system can provide information about system disturbances and their possible causes. It can also detect problem conditions throughout the system before they cause customer complaints, equipment malfunctions and even equipment damage or failure. Power quality problems are not limited to the utility side of the system. In fact, the majority of power quality problems are localized within customer facilities. Thus, power quality monitoring is not only an effective customer service strategy but also a way to protect a utility's reputation for quality power and service.

The protection relay has the following power quality monitoring functions.

- Voltage variation
- Voltage unbalance
- Current harmonics
- Voltage harmonics

The voltage unbalance and voltage variation functions are used for measuring short-duration voltage variations and monitoring voltage unbalance conditions in power transmission and distribution networks.

The voltage and current harmonics functions provide a method for monitoring the power quality by means of the current waveform distortion and voltage waveform distortion. The functions provides a short-term three-second average and a long-term demand for total demand distortion TDD and total harmonic distortion THD.

9. Fault location

The relay features an optional impedance-measuring fault location function suitable for locating short-circuits in radial distribution systems. Earth faults can be located in effectively and low-resistance earthed networks. Under circumstances where the fault current magnitude is at least of the same order of magnitude or higher than the load current, earth faults can also be located in isolated neutral distribution networks. The fault location function identifies the type of the fault and then calculates the distance to the fault point. An estimate of the fault resistance value is also calculated. The estimate provides information about the possible fault cause and the accuracy of the estimated distance to the fault point.

10. Disturbance recorder

The relay is provided with a disturbance recorder with up to 12 analog and 64 binary signal channels. The analog channels can be set to record either the waveform or the trend of the currents and voltages measured.

The analog channels can be set to trigger the recording function when the measured value falls below or exceeds the set values. The binary signal channels can be set to start a recording either on the rising or the falling edge of the binary signal or on both.

By default, the binary channels are set to record external or internal relay signals, for example, the start or trip signals of the relay stages, or external blocking or control signals. Binary relay signals, such as protection start and trip signals, or an external relay control signal via a binary input, can be set to trigger the recording. Recorded information is stored in a non-volatile memory and can be uploaded for subsequent fault analysis.

11. Event log

To collect sequence-of-events information, the relay has a non-volatile memory with a capacity of storing 1024 events with associated time stamps. The non-volatile memory retains its data also in case the relay temporarily loses its auxiliary supply. The event log facilitates detailed pre- and post-fault analyses of feeder faults and disturbances. The increased capacity to process and store data and events in the relay offers prerequisites to support the growing information demand of future network configurations.

The sequence-of-events information can be accessed either locally via the user interface on the relay's front panel, or remotely via the communication interface of the relay. The information can also be accessed using the Web browser-based user interface, either locally or remotely.

12. Recorded data

The relay has the capacity to store the records of the 128 latest fault events. The records enable the user to analyze the power system events. Each record includes current, voltage and angle values, time stamp and so on. The fault recording can be triggered by the start signal or the trip signal of a protection block, or by both. The available measurement modes include DFT, RMS and peak-to-peak. Fault records store relay measurement values at the moment when any protection function starts. In addition, the maximum demand current with time stamp is separately recorded. The records are stored in the non-volatile memory.

13. Condition monitoring

The condition monitoring functions of the relay constantly monitor the performance and the condition of the circuit breaker. The monitoring comprises the spring charging time, SF6 gas pressure, the travel time and the inactivity time of the circuit breaker.

The monitoring functions provide operational circuit breaker history data, which can be used for scheduling preventive circuit breaker maintenance.

In addition, the relay includes a runtime counter for monitoring of how many hours a protected device has been in operation thus enabling scheduling of time-based preventive maintenance of the device.

14. Trip-circuit supervision

The trip-circuit supervision continuously monitors the availability and operability of the trip circuit. It provides open-circuit monitoring both when the circuit breaker is in its closed and in its open position. It also detects loss of circuit-breaker control voltage.

15. Self-supervision

The relay's built-in self-supervision system continuously monitors the state of the relay hardware and the operation of the relay software. Any fault or malfunction detected is used for alerting the operator.

A permanent relay fault blocks the protection functions to prevent incorrect operation.

16. Fuse failure supervision

The fuse failure supervision detects failures between the voltage measurement circuit and the relay. The failures are detected either by the negative sequence-based algorithm or by the delta voltage and delta current algorithm. Upon the detection of a failure, the fuse failure supervision function activates an alarm and blocks voltage-dependent protection functions from unintended operation.

17. Current circuit supervision

Current circuit supervision is used for detecting faults in the current transformer secondary circuits. On detecting of a fault the current circuit supervision function activates an alarm LED and blocks certain protection functions to avoid unintended operation. The current circuit supervision function calculates the sum of the phase currents from the protection cores and compares the sum with the measured single reference current from a core balance current transformer or from separate cores in the phase current transformers.

18. Access control

To protect the relay from unauthorized access and to maintain information integrity, the relay is provided with a four-level, role-based authentication system with administrator-programmable individual passwords for the viewer, operator, engineer and administrator level. The access control applies to the front-panel user interface, the Web browser-based user interface and PCM600.

19. Inputs and outputs

REF620 can be selected to measure currents and voltages either with conventional current transducers and voltage transducers or with current sensors and voltage sensors. The relay variant with conventional transducers is equipped with three phase current inputs, one residual-current input, three phase voltage inputs, one residual-voltage input and one phase-to-phase voltage for syncrocheck input. In addition to current and voltage measurements, the relay's basic configuration includes 24 binary inputs and 14 binary outputs. The phase current inputs and the residual-current inputs are rated 1/5 A, that is, the inputs allow the connection of either 1 A or 5 A secondary current transformers. The optional sensitive residual-current input 0.2/1 A is normally used in applications requiring sensitive earth-fault protection and featuring core balance current transformers. The three phase voltage inputs and the residual-voltage input covers the rated voltages 60...

210 V. Both phase-to-phase voltages and phase-to-earth voltages can be connected.

The relay variant equipped with current and voltage sensors has three sensor inputs for the direct connection of three combisensors with RJ-45 connectors. As an alternative to the combisensors, separate current and voltage sensors can be utilized using adapters. Furthermore, the adapters also enable the use of sensors with Twin-BNC connectors. Additionally, the relay includes one conventional residual-current input 0.2/1 A normally used in applications requiring sensitive earth-fault protection and featuring core balance current transformers. In addition to current and voltage measurements, the relay's basic configuration includes 16 binary inputs and 14 binary outputs.

As an optional addition, the relay's basic configuration includes one empty slot which can be equipped with one of the following optional modules. The first option, additional binary inputs and outputs module, adds eight binary inputs and four binary outputs to the relay. This option is especially needed when connecting the relay to several controllable objects, still leaving room for additional inputs and outputs for other signals needed in configuration. The second option, an additional RTD/mA input module, increases the relay with six RTD inputs and two mA inputs when additional sensor measurements for example for temperatures, pressures, levels and so on are of interest. The third option is a high-speed output board including eight binary inputs and three high-speed outputs. The high-speed outputs have a shorter activation time compared to the

conventional mechanical output relays, shortening the overall relay operation time by 4...6 ms with very time-critical applications like arc protection. The high-speed outputs are freely configurable in the relay application and not limited to arc protection only.

The rated values of the current and voltage inputs are settable parameters of the relay. In addition, the binary input thresholds are selectable within the range of 16...176 V DC by adjusting the relay's parameter settings.

All binary inputs and outputs contacts are freely configurable with the signal matrix or application configuration functionality of PCM600.

See the Input/output overview table and the terminal diagrams for more detailed information about the inputs and outputs.

If the number of the relay's own inputs and outputs does not cover all the intended purposes, connecting to an external input or output module, for example RIO600, increases the number of binary inputs and outputs utilizable in the relay configuration. In this case, the external inputs and outputs are connected to the relay via IEC 61850 GOOSE to reach fast reaction times between the relay and RIO600 information. The needed binary input and output connections between the relay and RIO600 units can be configured in a PCM600 tool and then utilized in the relay configuration.

Table 3. Input/output overview

Default conf.	Order code digit		Analog channels			Binary channels		RTD	mA
	5-6	7-8	CT	VT	Combi sensor	BI	BO		
A	AA/AB	AA	4	5	-	32	4 PO + 14 SO	-	-
		AB				24	4 PO + 10 SO	6	2
		AC				32	4 PO + 10 SO + 3 HSO	-	-
		NN				24	4 PO + 10 SO	-	-
B	AC	AA	1	-	3	24	4 PO + 14 SO	-	-
		AB				16	4 PO + 10 SO	6	2
		AC				24	4 PO + 10 SO + 3 HSO	-	-
		NN				16	4 PO + 10 SO	-	-

20. Station communication

The relay supports a range of communication protocols including IEC 61850 Edition 1 and Edition 2, IEC 61850-9-2 LE, IEC 60870-5-103, Modbus® and DNP3. Profibus DPV1 communication protocol is supported with using the protocol converter SPA-ZC 302. Operational information and controls are available through these protocols. However, some communication functionality, for example, horizontal communication between the relays, is only enabled by the IEC 61850 communication protocol.

The IEC 61850 protocol is a core part of the relay as the protection and control application is fully based on standard modelling. The relay supports Edition 2 and Edition 1 versions of the standard. With Edition 2 support, the relay has the latest functionality modelling for substation applications and the best interoperability for modern substations. It incorporates also the full support of standard device mode functionality supporting different test applications. Control applications can utilize the new safe and advanced station control authority feature.

The IEC 61850 communication implementation supports monitoring and control functions. Additionally, parameter settings, disturbance recordings and fault records can be accessed using the IEC 61850 protocol. Disturbance recordings are available to any Ethernet-based application in the standard COMTRADE file format. The relay supports simultaneous event reporting to five different clients on the station bus. The relay can exchange data with other devices using the IEC 61850 protocol.

The relay can send binary and analog signals to other devices using the IEC 61850-8-1 GOOSE (Generic Object Oriented Substation Event) profile. Binary GOOSE messaging can, for example, be employed for protection and interlocking-based protection schemes. The relay meets the GOOSE performance requirements for tripping applications in distribution substations, as defined by the IEC 61850 standard (<10 ms data exchange between the devices). The relay also supports the sending and receiving of analog values using GOOSE messaging. Analog GOOSE messaging enables easy transfer of analog measurement values over the station bus, thus facilitating for example the sending of measurement values between the relays when controlling parallel running transformers.

The relay also supports IEC 61850 process bus by sending sampled values of analog currents and voltages and by receiving sampled values of voltages. With this functionality the galvanic interpanel wiring can be replaced with Ethernet communication. The measured values are transferred as sampled values using IEC 61850-9-2 LE protocol. The intended application for sampled values shares the voltages to other 620 series relays, having voltage based functions and 9-2 support. 620 relays with process bus based applications use IEEE 1588 for high accuracy time synchronization.

For redundant Ethernet communication, the relay offers either two optical or two galvanic Ethernet network interfaces. A third port with galvanic Ethernet network interface is also available. The third Ethernet interface provides connectivity for any other Ethernet device to an IEC 61850 station bus inside a switchgear bay, for example connection of a Remote I/O. Ethernet network redundancy can be achieved using the high-availability seamless redundancy (HSR) protocol or the parallel redundancy protocol (PRP) or a with self-healing ring using RSTP in managed switches. Ethernet redundancy can be applied to Ethernet-based IEC 61850, Modbus and DNP3 protocols.

The IEC 61850 standard specifies network redundancy which improves the system availability for the substation communication. The network redundancy is based on two complementary protocols defined in the IEC 62439-3 standard: PRP and HSR protocols. Both protocols are able to overcome a failure of a link or switch with a zero switch-over time. In both protocols, each network node has two identical Ethernet ports dedicated for one network connection. The protocols rely on the duplication of all transmitted information and provide a zero switch-over time if the links or switches fail, thus fulfilling all the stringent real-time requirements of substation automation.

In PRP, each network node is attached to two independent networks operated in parallel. The networks are completely separated to ensure failure independence and can have different topologies. The networks operate in parallel, thus providing zero-time recovery and continuous checking of redundancy to avoid failures.

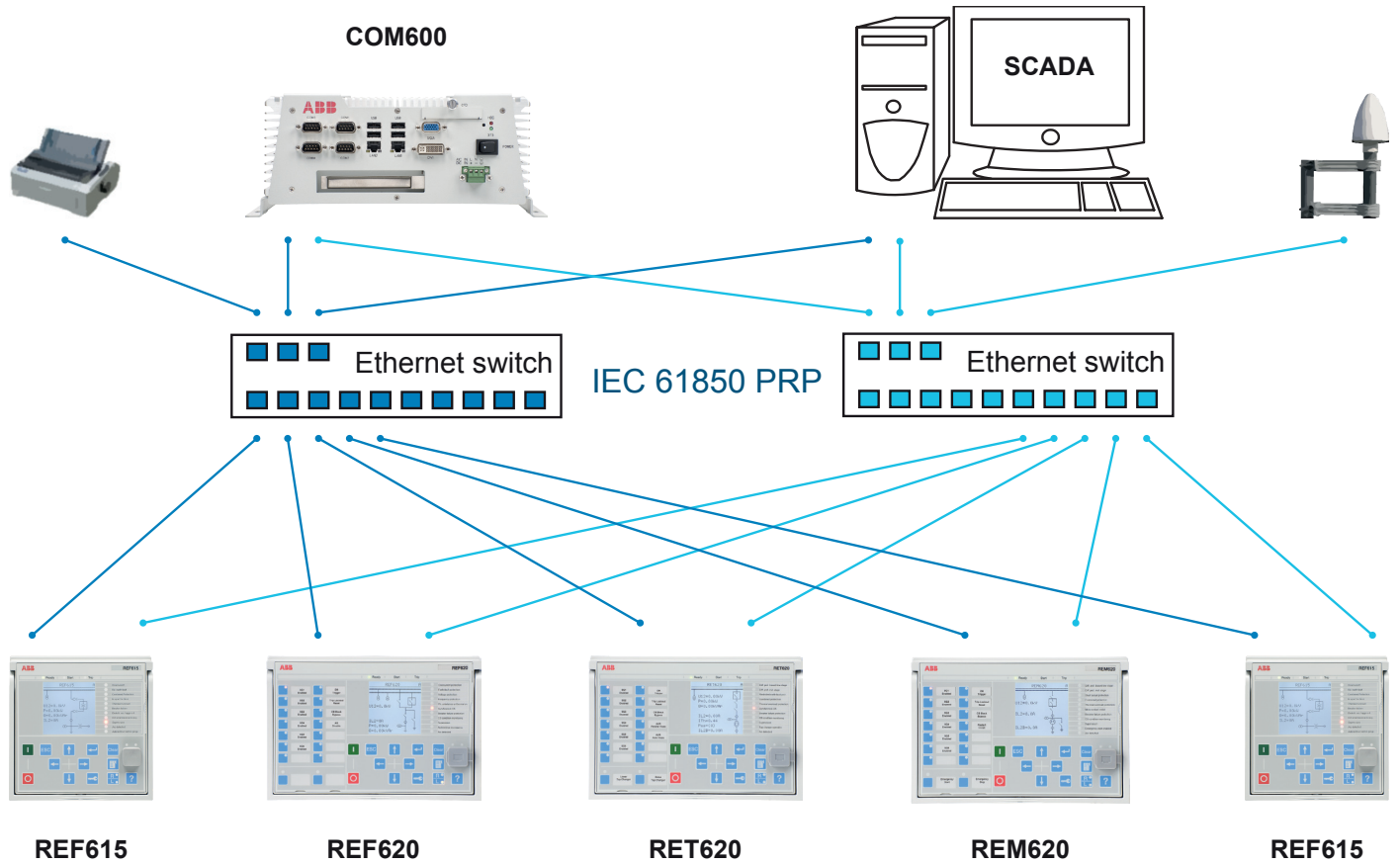

Figure 15. Parallel redundancy protocol (PRP) solution

HSR applies the PRP principle of parallel operation to a single ring. For each message sent, the node sends two frames, one through each port. Both frames circulate in opposite directions over the ring. Every node forwards the frames it receives from one port to another to reach the next node. When the originating sender node receives the frame it sent, the sender

node discards the frame to avoid loops. The HSR ring with 620 series relays supports the connection of up to 30 relays. If more than 30 relays are connected, it is recommended to split the network into several rings to guarantee the performance for real-time applications.

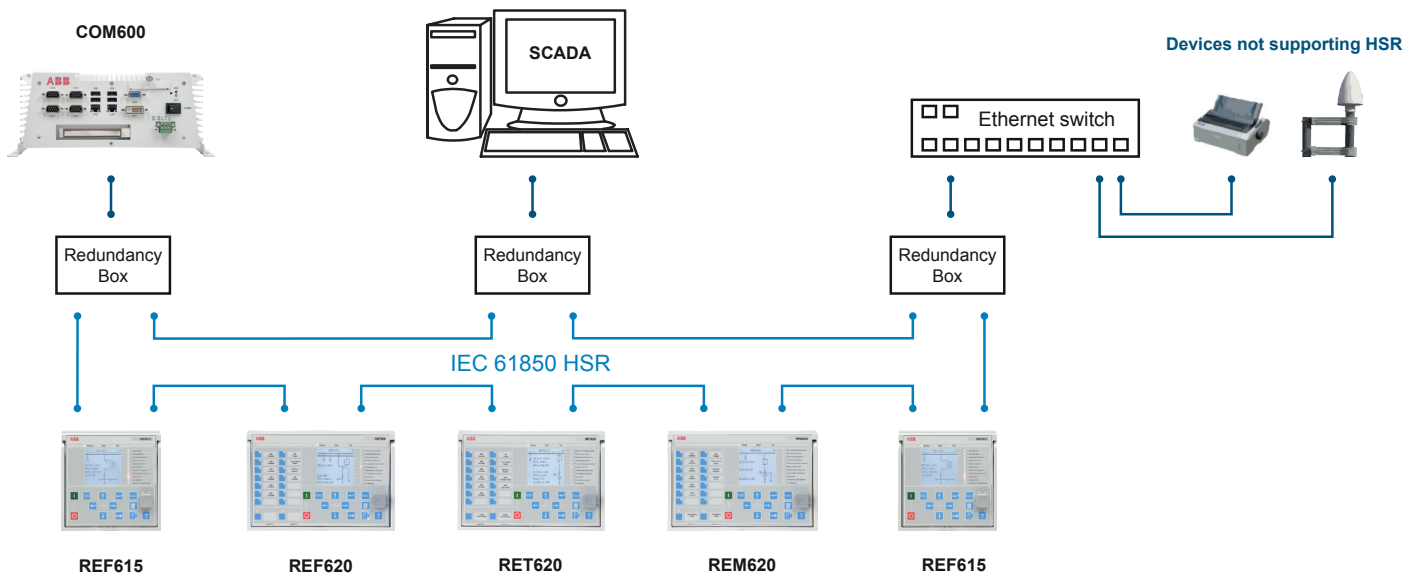

Figure 16. High availability seamless redundancy (HSR) solution

The choice between the HSR and PRP redundancy protocols depends on the required functionality, cost and complexity.

The self-healing Ethernet ring solution enables a cost-efficient communication ring controlled by a managed switch with standard Rapid Spanning Tree I Protocol (RSTP) support. The managed switch controls the consistency of the loop, routes the data and corrects the data flow in case of a communication

switch-over. The relays in the ring topology act as unmanaged switches forwarding unrelated data traffic. The Ethernet ring solution supports the connection of up to thirty 620 series relays. If more than 30 relays are connected, it is recommended to split the network into several rings. The self-healing Ethernet ring solution avoids single point of failure concerns and improves the reliability of the communication.

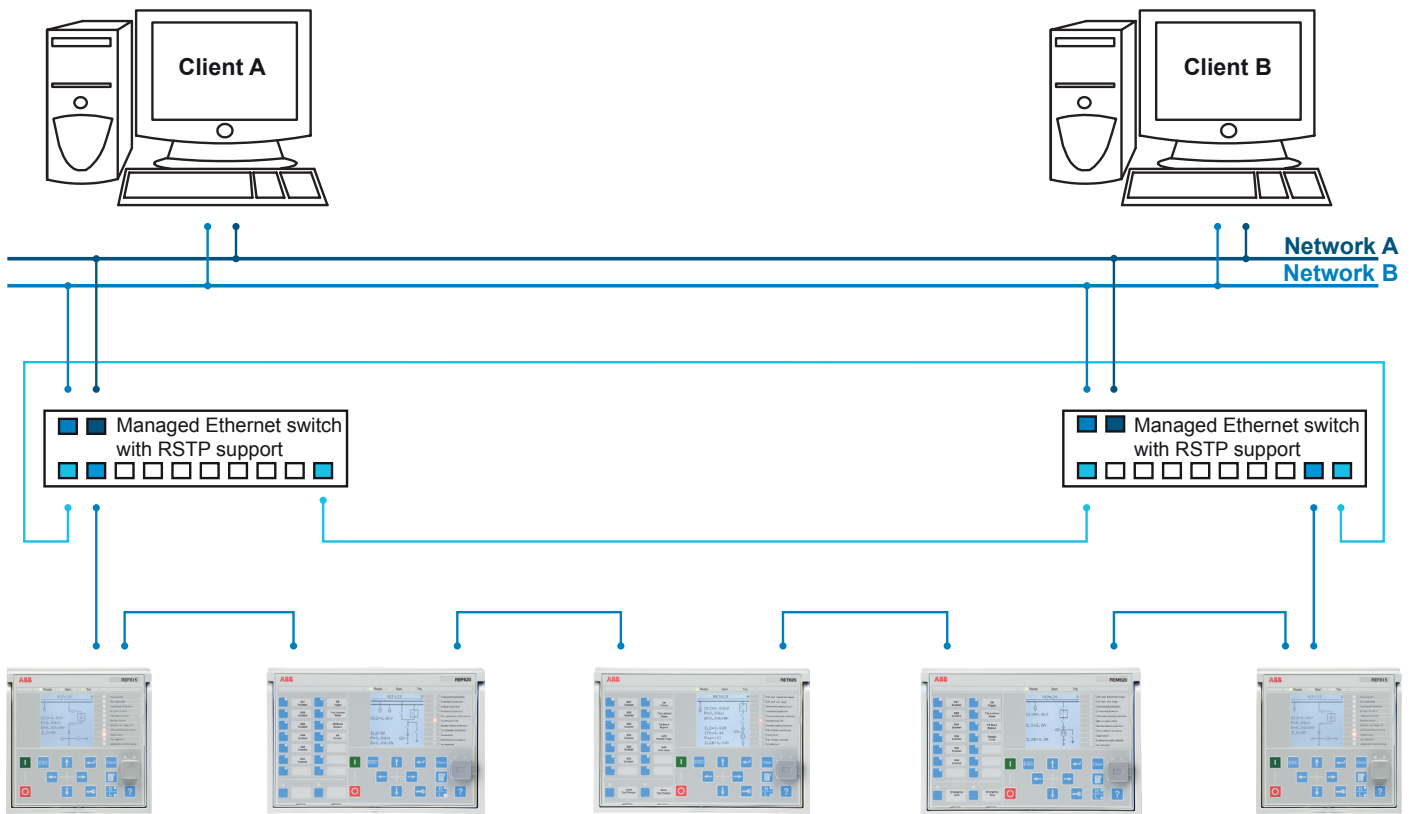

Figure 17. Self-healing Ethernet ring solution

All communication connectors, except for the front port connector, are placed on integrated optional communication modules. The relay can be connected to Ethernet-based communication systems via the RJ-45 connector (100Base-TX) or the fiber-optic LC connector (100Base-FX). If a connection to the serial bus is required, the 9-pin RS-485 screw-terminal can be used. An optional serial interface is available for RS-232 communication.

Modbus implementation supports RTU, ASCII and TCP modes. Besides standard Modbus functionality, the relay supports retrieval of time-stamped events, changing the active setting group and uploading of the latest fault records. If a Modbus TCP connection is used, five clients can be connected to the relay simultaneously. Further, Modbus serial and Modbus TCP can be used in parallel, and if required both IEC 61850 and Modbus protocols can be run simultaneously.

The IEC 60870-5-103 implementation supports two parallel serial bus connections to two different masters. Besides basic standard functionality, the relay supports changing of the active setting group and uploading of disturbance recordings in IEC 60870-5-103 format. Further, IEC 60870-5-103 can be used at the same time with the IEC 61850 protocol.

DNP3 supports both serial and TCP modes for connection up to five masters. Changing of the active setting and reading fault

records are supported. DNP serial and DNP TCP can be used in parallel. If required, both IEC 61850 and DNP protocols can be run simultaneously.

620 series supports Profibus DPV1 with support of SPA-ZC 302 Profibus adapter. If Profibus is required the relay must be ordered with Modbus serial options. Modbus implementation includes SPA-protocol emulation functionality. This functionality enables connection to SPA-ZC 302.

When the relay uses the RS-485 bus for the serial communication, both two- and four wire connections are supported. Termination and pull-up/down resistors can be configured with jumpers on the communication card so external resistors are not needed.

The relay supports the following time synchronization methods with a time-stamping resolution of 1 ms.

Ethernet-based

- SNTP (Simple Network Time Protocol)

With special time synchronization wiring

- IRIG-B (Inter-Range Instrumentation Group - Time Code Format B)

The relay supports the following high accuracy time synchronization method with a time-stamping resolution of 4 μ s required especially in process bus applications.

- PTP (IEEE 1588) v2 with Power Profile

The IEEE 1588 support is included in all variants having a redundant Ethernet communication module.

IEEE 1588 v2 features

- Ordinary Clock with Best Master Clock algorithm
- One-step Transparent Clock for Ethernet ring topology
- 1588 v2 Power Profile
- Receive (slave): 1-step/2-step
- Transmit (master): 1-step

- Layer 2 mapping
- Peer to peer delay calculation
- Multicast operation

Required accuracy of grandmaster clock is +/-1 μ s. The relay can work as a master clock per BMC algorithm if the external grandmaster clock is not available for short term.

The IEEE 1588 support is included in all variants having a redundant Ethernet communication module.

In addition, the relay supports time synchronization via Modbus, DNP3 and IEC 60870-5-103 serial communication protocols.

Table 4. Supported station communication interfaces and protocols

Interfaces/Protocols	Ethernet		Serial	
	100BASE-TX RJ-45	100BASE-FX LC	RS-232/RS-485	Fiber-optic ST
IEC 61850-8-1	•	•	-	-
IEC 61850-9-2 LE	•	•	-	-
MODBUS RTU/ASCII	-	-	•	•
MODBUS TCP/IP	•	•	-	-
DNP3 (serial)	-	-	•	•
DNP3 TCP/IP	•	•	-	-
IEC 60870-5-103	-	-	•	•

• = Supported

Feeder Protection and Control	1MRS757844 E
REF620	
Product version: 2.0 FP1	

21. Technical data

Table 5. Dimensions

Description	Value
Width	Frame 262.2 mm
	Case 246 mm
Height	Frame 177 mm, 4U
	Case 160 mm
Depth	201 mm
Weight	Complete protection relay max. 5.0 kg
	Plug-in unit only max. 2.9 kg

Table 6. Power supply

Description	Type 1	Type 2
U _{aux} nominal	100, 110, 120, 220, 240 V AC, 50 and 60 Hz	24, 30, 48, 60 V DC
	48, 60, 110, 125, 220, 250 V DC	
Maximum interruption time in the auxiliary DC voltage without resetting the relay	50 ms at U _n rated	
U _{aux} variation	38...110% of U _n (38...264 V AC)	50...120% of U _n (12...72 V DC)
	80...120% of U _n (38.4...300 V DC)	
Start-up threshold	19.2 V DC (24 V DC × 80%)	
Burden of auxiliary voltage supply under quiescent (P _q)/operating condition	DC <18.0 W (nominal ¹)/<22.5 W (max ²) AC <19.0 W (nominal ¹)/<23.0 W (max ²)	DC <18.5 W (nominal ¹)/<22.5 W (max ²)
Ripple in the DC auxiliary voltage	Max 15% of the DC value (at frequency of 100 Hz)	
Fuse type	T4A/250 V	

- 1) During the power consumption measurement, the relay is powered at rated auxiliary energizing voltage and the energizing quantities are energized without any binary output being active
- 2) During the power consumption measurement, the relay is powered at rated auxiliary energizing voltage and the energizing quantities are energized to activate at least half of the binary outputs

Table 7. Energizing inputs

Description		Value	
Rated frequency		50/60 Hz	
Current inputs	Rated current, I_n	0.2/1 A ¹⁾	1/5 A ²⁾
	Thermal withstand capability:		
	• Continuously	4 A	20 A
	• For 1 s	100 A	500 A
	Dynamic current withstand:		
• Half-wave value	250 A	1250 A	
Input impedance		<100 mΩ	<20 mΩ
Voltage inputs	Rated voltage	60...210 V AC	
	Voltage withstand:		
	• Continuous	240 V AC	
	• For 10 s	360 V AC	
Burden at rated voltage		<0.05 VA	

1) Ordering option for residual current input

2) Residual current and/or phase current

Table 8. Energizing inputs (sensors)

Description		Value	
Current sensor input	Rated current voltage (in secondary side)	75...9000 mV ¹⁾	
	Continuous voltage withstand	125 V	
	Input impedance at 50/60 Hz	2...3 MΩ ²⁾	
Voltage sensor input	Rated voltage	6...30 kV ³⁾	
	Continuous voltage withstand	50 V	
	Input impedance at 50/60 Hz	3 MΩ	

1) Equals the current range of 40...4000 A with a 80 A, 3 mV/Hz Rogowski

2) Depending on the used nominal current (hardware gain)

3) This range is covered (up to 2 × rated) with sensor division ratio of 10 000:1

Table 9. Binary inputs

Description	Value
Operating range	±20% of the rated voltage
Rated voltage	24...250 V DC
Current drain	1.6...1.9 mA
Power consumption	31.0...570.0 mW
Threshold voltage	16...176 V DC
Reaction time	<3 ms

Table 10. RTD/mA measurement

Description		Value	
RTD inputs	Supported RTD sensors	100 Ω platinum	TCR 0.00385 (DIN 43760)
		250 Ω platinum	TCR 0.00385
		100 Ω nickel	TCR 0.00618 (DIN 43760)
		120 Ω nickel	TCR 0.00618
		250 Ω nickel	TCR 0.00618
		10 Ω copper	TCR 0.00427
		Supported resistance range	0...2 k Ω
Maximum lead resistance (three-wire measurement)	25 Ω per lead		
Isolation	2 kV (inputs to protective earth)		
Response time	<4 s		
RTD/resistance sensing current	Maximum 0.33 mA rms		
Operation accuracy	Resistance	Temperature	
	$\pm 2.0\%$ or $\pm 1 \Omega$	$\pm 1^\circ\text{C}$ 10 Ω copper: $\pm 2^\circ\text{C}$	
mA inputs	Supported current range	0...20 mA	
	Current input impedance	44 $\Omega \pm 0.1\%$	
	Operation accuracy	$\pm 0.5\%$ or ± 0.01 mA	

Table 11. Signal output with high make and carry

Description	Value ¹⁾
Rated voltage	250 V AC/DC
Continuous contact carry	5 A
Make and carry for 3.0 s	15 A
Make and carry for 0.5 s	30 A
Breaking capacity when the control-circuit time constant L/R <40 ms	1 A/0.25 A/0.15 A
Minimum contact load	100 mA at 24 V AC/DC

- 1) X100: SO1
X105: SO1, SO2, when any of the protection relays is equipped with BIO0005.
X110: SO1, SO2 when REF620 or RET620 is equipped with BIO0005
X115: SO1, SO2 when REF620 or REM620 is equipped with BIO0005

REF620

Product version: 2.0 FP1

Table 12. Signal outputs and IRF output

Description	Value ¹⁾
Rated voltage	250 V AC/DC
Continuous contact carry	5 A
Make and carry for 3.0 s	10 A
Make and carry for 0.5 s	15 A
Breaking capacity when the control-circuit time constant L/R <40 ms, at 48/110/220 V DC	1 A/0.25 A/0.15 A
Minimum contact load	10 mA at 5 V AC/DC

1) X100: IRF,SO2
X105: SO3, SO4, when any of the protection relays is equipped with BIO0005
X110: SO3, SO4, when REF620 or RET620 is equipped with BIO0005
X115:SO3, SO4, when REF620 or REM620 is equipped with BIO0005

Table 13. Double-pole power outputs with TCS function X100: PO3 and PO4

Description	Value ¹⁾
Rated voltage	250 V AC/DC
Continuous contact carry	8 A
Make and carry for 3.0 s	15 A
Make and carry for 0.5 s	30 A
Breaking capacity when the control-circuit time constant L/R <40 ms, at 48/110/220 V DC (two contacts connected in a series)	5 A/3 A/1 A
Minimum contact load	100 mA at 24 V AC/DC
Trip-circuit monitoring (TCS)	
• Control voltage range	20...250 V AC/DC
• Current drain through the monitoring circuit	~1.5 mA
• Minimum voltage over the TCS contact	20 V AC/DC (15...20 V)

1) PSM0003: PO3, PSM0004: PO3, PSM0003: PO4 and PSM0004: PO4.

Table 14. Single-pole power output relays X100: PO1 and PO2

Description	Value
Rated voltage	250 V AC/DC
Continuous contact carry	8 A
Make and carry for 3.0 s	15 A
Make and carry for 0.5 s	30 A
Breaking capacity when the control-circuit time constant L/R <40 ms, at 48/110/220 V DC	5 A/3 A/1 A
Minimum contact load	100 mA at 24 V AC/DC

Table 15. High-speed output HSO

Description	Value ¹⁾
Rated voltage	250 V AC/DC
Continuous contact carry	6 A
Make and carry for 3.0 s	15 A
Make and carry for 0.5 s	30 A
Breaking capacity when the control-circuit time constant L/R <40 ms, at 48/110/220 V DC	5 A/3 A/1 A
Operate time	<1 ms
Reset	<20 ms, resistive load

1) X105: HSO1, HSO2 HSO3, when any of the protection relays is equipped with BIO0007

Table 16. Front port Ethernet interfaces

Ethernet interface	Protocol	Cable	Data transfer rate
Front	TCP/IP protocol	Standard Ethernet CAT 5 cable with RJ-45 connector	10 Mbits/s

Table 17. Station communication link, fiber optic

Connector	Fiber type ¹⁾	Wave length	Typical max. length ²⁾	Permitted path attenuation ³⁾
LC	MM 62.5/125 or 50/125 μ m glass fiber core	1300 nm	2 km	<8 dB
ST	MM 62.5/125 or 50/125 μ m glass fiber core	820...900 nm	1 km	<11 dB

1) (MM) multi-mode fiber, (SM) single-mode fiber

2) Maximum length depends on the cable attenuation and quality, the amount of splices and connectors in the path.

3) Maximum allowed attenuation caused by connectors and cable together

Table 18. IRIG-B

Description	Value
IRIG time code format	B004, B005 ¹⁾
Isolation	500V 1 min
Modulation	Unmodulated
Logic level	5 V TTL
Current consumption	<4 mA
Power consumption	<20 mW

1) According to the 200-04 IRIG standard

Table 19. Lens sensor and optical fiber for arc protection

Description	Value
Fiber optic cable including lens	1.5 m, 3.0 m or 5.0 m
Normal service temperature range of the lens	-40...+100°C
Maximum service temperature range of the lens, max 1 h	+140°C
Minimum permissible bending radius of the connection fiber	100 mm

Table 20. Degree of protection of flush-mounted protection relay

Description	Value
Front side	IP 54
Rear side, connection terminals	IP 20

Table 21. Environmental conditions

Description	Value
Operating temperature range	-25...+55°C (continuous)
Short-time service temperature range	-40...+85°C (<16h) ¹⁾²⁾
Relative humidity	<93%, non-condensing
Atmospheric pressure	86...106 kPa
Altitude	Up to 2000 m
Transport and storage temperature range	-40...+85°C

1) Degradation in MTBF and HMI performance outside the temperature range of -25...+55 °C

2) For relays with an LC communication interface the maximum operating temperature is +70 °C

Table 22. Electromagnetic compatibility tests

Description	Type test value	Reference
1 MHz/100 kHz burst disturbance test		IEC 61000-4-18 IEC 60255-26, class III IEEE C37.90.1-2002
<ul style="list-style-type: none"> • Common mode • Differential mode 	2.5 kV 2.5 kV	
3 MHz, 10 MHz and 30 MHz burst disturbance test		IEC 61000-4-18 IEC 60255-26, class III
<ul style="list-style-type: none"> • Common mode 	2.5 kV	
Electrostatic discharge test		IEC 61000-4-2 IEC 60255-26 IEEE C37.90.3-2001
<ul style="list-style-type: none"> • Contact discharge • Air discharge 	8 kV 15 kV	
Radio frequency interference test		IEC 61000-4-6 IEC 60255-26, class III
	10 V (rms) f = 150 kHz...80 MHz	IEC 61000-4-3 IEC 60255-26, class III
	10 V/m (rms) f = 80...2700 MHz	ENV 50204 IEC 60255-26, class III
	10 V/m f = 900 MHz	
Fast transient disturbance test		IEC 61000-4-4 IEC 60255-26 IEEE C37.90.1-2002
<ul style="list-style-type: none"> • All ports 	4 kV	
Surge immunity test		IEC 61000-4-5 IEC 60255-26
<ul style="list-style-type: none"> • Communication • Other ports 	1 kV, line-to-earth 4 kV, line-to-earth 2 kV, line-to-line	
Power frequency (50 Hz) magnetic field immunity test		IEC 61000-4-8
<ul style="list-style-type: none"> • Continuous • 1...3 s 	300 A/m 1000 A/m	
Pulse magnetic field immunity test		IEC 61000-4-9
	1000 A/m 6.4/16 µs	
Damped oscillatory magnetic field immunity test		IEC 61000-4-10
<ul style="list-style-type: none"> • 2 s • 1 MHz 	100 A/m 400 transients/s	
Voltage dips and short interruptions		IEC 61000-4-11
	30%/10 ms 60%/100 ms 60%/1000 ms >95%/5000 ms	
Power frequency immunity test		IEC 61000-4-16 IEC 60255-26, class A
<ul style="list-style-type: none"> • Common mode 	300 V rms	

Table 22. Electromagnetic compatibility tests, continued

Description	Type test value	Reference
• Differential mode	150 V rms	
Conducted common mode disturbances	15 Hz...150 kHz Test level 3 (10/1/10 V rms)	IEC 61000-4-16
Emission tests		EN 55011, class A IEC 60255-26 CISPR 11 CISPR 12
• Conducted		
0.15...0.50 MHz	<79 dB (μV) quasi peak <66 dB (μV) average	
0.5...30 MHz	<73 dB (μV) quasi peak <60 dB (μV) average	
• Radiated		
30...230 MHz	<40 dB (μV/m) quasi peak, measured at 10 m distance	
230...1000 MHz	<47 dB (μV/m) quasi peak, measured at 10 m distance	
1...3 GHz	<76 dB (μV/m) peak <56 dB (μV/m) average, measured at 3 m distance	
3...6 GHz	<80 dB (μV/m) peak <60 dB (μV/m) average, measured at 3 m distance	

Table 23. Insulation tests

Description	Type test value	Reference
Dielectric tests	2 kV, 50 Hz, 1 min 500 V, 50 Hz, 1 min, communication	IEC 60255-27
Impulse voltage test	5 kV, 1.2/50 μs, 0.5 J 1 kV, 1.2/50 μs, 0.5 J, communication	IEC 60255-27
Insulation resistance measurements	>100 MΩ, 500 V DC	IEC 60255-27
Protective bonding resistance	<0.1 Ω, 4 A, 60 s	IEC 60255-27

Table 24. Mechanical tests

Description	Reference	Requirement
Vibration tests (sinusoidal)	IEC 60068-2-6 (test Fc) IEC 60255-21-1	Class 2
Shock and bump test	IEC 60068-2-27 (test Ea shock) IEC 60068-2-29 (test Eb bump) IEC 60255-21-2	Class 2
Seismic test	IEC 60255-21-3	Class 2

Table 25. Environmental tests

Description	Type test value	Reference
Dry heat test	<ul style="list-style-type: none"> 96 h at +55°C 16 h at +85°C¹⁾ 	IEC 60068-2-2
Dry cold test	<ul style="list-style-type: none"> 96 h at -25°C 16 h at -40°C 	IEC 60068-2-1
Damp heat test	<ul style="list-style-type: none"> 6 cycles (12 h + 12 h) at +25°C...+55°C, humidity >93% 	IEC 60068-2-30
Change of temperature test	<ul style="list-style-type: none"> 5 cycles (3 h + 3 h) at -25°C...+55°C 	IEC60068-2-14
Storage test	<ul style="list-style-type: none"> 96 h at -40°C 96 h at +85°C 	IEC 60068-2-1 IEC 60068-2-2

1) For relays with an LC communication interface the maximum operating temperature is +70°C

Table 26. Product safety

Description	Reference
LV directive	2006/95/EC
Standard	EN 60255-27 (2013) EN 60255-1 (2009)

Table 27. EMC compliance

Description	Reference
EMC directive	2004/108/EC
Standard	EN 60255-26 (2013)

Table 28. RoHS compliance

Description
Complies with RoHS directive 2002/95/EC

Protection functions

Table 29. Three-phase non-directional overcurrent protection (PHxPTOC)

Characteristic	Value			
Operation accuracy	Depending on the frequency of the measured current: $f_n \pm 2$ Hz			
	PHLPTOC	$\pm 1.5\%$ of the set value or $\pm 0.002 \times I_n$		
	PHHPTOC and PHIPTOC	$\pm 1.5\%$ of set value or $\pm 0.002 \times I_n$ (at currents in the range of $0.1 \dots 10 \times I_n$) $\pm 5.0\%$ of the set value (at currents in the range of $10 \dots 40 \times I_n$)		
Start time ¹⁾²⁾		Minimum	Typical	Maximum
	PHIPTOC: $I_{\text{Fault}} = 2 \times \text{set Start value}$ $I_{\text{Fault}} = 10 \times \text{set Start value}$	16 ms	19 ms	23 ms
		11 ms	12 ms	14 ms
	PHHPTOC and PHLPTOC: $I_{\text{Fault}} = 2 \times \text{set Start value}$	23 ms	26 ms	29 ms
Reset time	Typically 40 ms			
Reset ratio	Typically 0.96			
Retardation time	<30 ms			
Operate time accuracy in definite time mode	$\pm 1.0\%$ of the set value or ± 20 ms			
Operate time accuracy in inverse time mode	$\pm 5.0\%$ of the theoretical value or ± 20 ms ³⁾			
Suppression of harmonics	RMS: No suppression DFT: -50 dB at $f = n \times f_n$, where $n = 2, 3, 4, 5, \dots$ Peak-to-Peak: No suppression P-to-P+backup: No suppression			

1) Set *Operate delay time* = 0,02 s, *Operate curve type* = IEC definite time, *Measurement mode* = default (depends on stage), current before fault = $0.0 \times I_n$, $f_n = 50$ Hz, fault current in one phase with nominal frequency injected from random phase angle, results based on statistical distribution of 1000 measurements

2) Includes the delay of the signal output contact

3) Includes the delay of the heavy-duty output contact

Table 30. Three-phase non-directional overcurrent protection (PHxPTOC) main settings

Parameter	Function	Value (Range)	Step
Start value	PHLPTOC	0.05...5.00 × I _n	0.01
	PHHPTOC	0.10...40.00 × I _n	0.01
	PHIPTOC	1.00...40.00 × I _n	0.01
Time multiplier	PHLPTOC	0.05...15.00	0.01
	PHHPTOC	0.05...15.00	0.01
Operate delay time	PHLPTOC	40...200000 ms	10
	PHHPTOC	40...200000 ms	10
	PHIPTOC	20...200000 ms	10
Operating curve type ¹⁾	PHLPTOC	Definite or inverse time Curve type: 1, 2, 3, 4, 5, 6, 7, 8, 9, 10, 11, 12, 13, 14, 15, 17, 18, 19	
	PHHPTOC	Definite or inverse time Curve type: 1, 3, 5, 9, 10, 12, 15, 17	
	PHIPTOC	Definite time	

1) For further reference, see Operation characteristics table

Table 31. Three-phase directional overcurrent protection (DPHxPDOC)

Characteristic	Value
Operation accuracy	Depending on the frequency of the current/voltage measured: f _n ±2 Hz DPHLPDOC Current: ±1.5% of the set value or ±0.002 × I _n Voltage: ±1.5% of the set value or ±0.002 × U _n Phase angle: ±2°
	DPHHPDOC Current: ±1.5% of the set value or ±0.002 × I _n (at currents in the range of 0.1...10 × I _n) ±5.0% of the set value (at currents in the range of 10...40 × I _n) Voltage: ±1.5% of the set value or ±0.002 × U _n Phase angle: ±2°
Start time ¹⁾²⁾	Minimum Typical Maximum I _{Fault} = 2.0 × set Start value 39 ms 43 ms 47 ms
	Typically 40 ms
Reset time	Typically 40 ms
Reset ratio	Typically 0.96
Retardation time	<35 ms
Operate time accuracy in definite time mode	±1.0% of the set value or ±20 ms
Operate time accuracy in inverse time mode	±5.0% of the theoretical value or ±20 ms ³⁾
Suppression of harmonics	DFT: -50 dB at f = n × f _n , where n = 2, 3, 4, 5,...

1) Measurement mode and Pol quantity = default, current before fault = 0.0 × I_n, voltage before fault = 1.0 × U_n, f_n = 50 Hz, fault current in one phase with nominal frequency injected from random phase angle, results based on statistical distribution of 1000 measurements

2) Includes the delay of the signal output contact

3) Maximum Start value = 2.5 × I_n, Start value multiples in range of 1.5...20

Table 32. Three-phase directional overcurrent protection (DPHxPDOC) main settings

Parameter	Function	Value (Range)	Step
Start value	DPHLPDOC	0.05...5.00 × I _n	0.01
	DPHHPDOC	0.10...40.00 × I _n	0.01
Time multiplier	DPHxPDOC	0.05...15.00	0.01
Operate delay time	DPHxPDOC	40...200000 ms	10
Operating curve type ¹⁾	DPHLPDOC	Definite or inverse time Curve type: 1, 2, 3, 4, 5, 6, 7, 8, 9, 10, 11, 12, 13, 14, 15, 17, 18, 19	
	DPHHPDOC	Definite or inverse time Curve type: 1, 3, 5, 9, 10, 12, 15, 17	
Directional mode	DPHxPDOC	1 = Non-directional 2 = Forward 3 = Reverse	-
Characteristic angle	DPHxPDOC	-179...180°	1

1) For further reference, refer to the Operating characteristics table

Table 33. Three-phase voltage-dependent overcurrent protection (PHPVOC)

Characteristic	Value
Operation accuracy	Depending on the frequency of the measured current and voltage: f _n ±2 Hz Current: ±1.5% of the set value or ± 0.002 × I _n Voltage: ±1.5% of the set value or ±0.002 × U _n
Start time ¹⁾²⁾	Typically 26 ms
Reset time	Typically 40 ms
Reset ratio	Typically 0.96
Operate time accuracy in definite time mode	±1.0% of the set value or ±20 ms
Operate time accuracy in inverse time mode	±5.0% of the set value or ±20 ms
Suppression of harmonics	-50 dB at f = n × f _n , where n = 2, 3, 4, 5,...

1) *Measurement mode* = default, current before fault = 0.0 × I_n, f_n = 50 Hz, fault current in one phase with nominal frequency injected from random phase angle, results based on statistical distribution of 1000 measurements

2) Includes the delay of the signal output contact

Table 34. Three-phase voltage-dependent overcurrent protection (PHPVOC) main settings

Parameter	Function	Value (Range)	Step
Start value	PHPVOC	0.05...5.00 × I _n	0.01
Start value low	PHPVOC	0.05...1.00 × I _n	0.01
Voltage high limit	PHPVOC	0.01...1.00 × U _n	0.01
Voltage low limit	PHPVOC	0.01...1.00 × U _n	0.01
Start value Mult	PHPVOC	0.8...10.0	0.1
Time multiplier	PHPVOC	0.05...15.00	0.01
Operating curve type ¹⁾	PHPVOC	Definite or inverse time Curve type: 1, 2, 3, 4, 5, 6, 7, 8, 9, 10, 11, 12, 13, 14, 15, 17, 18, 19	
Operate delay time	PHPVOC	40...200000 ms	10

1) For further reference, see Operation characteristics table

Table 35. Non-directional earth-fault protection (EFxPTOC)

Characteristic	Value			
Operation accuracy	Depending on the frequency of the measured current: f _n ±2 Hz			
	EFLPTOC	±1.5% of the set value or ±0.002 × I _n		
	EFHPTOC and EFIPTOC	±1.5% of set value or ±0.002 × I _n (at currents in the range of 0.1...10 × I _n) ±5.0% of the set value (at currents in the range of 10...40 × I _n)		
Start time ¹⁾²⁾		Minimum	Typical	Maximum
	EFIPTOC: I _{Fault} = 2 × set <i>Start value</i> I _{Fault} = 10 × set <i>Start value</i>	16 ms	19 ms	23 ms
		11 ms	12 ms	14 ms
EFHPTOC and EFLPTOC: I _{Fault} = 2 × set <i>Start value</i>	23 ms	26 ms	29 ms	
Reset time	Typically 40 ms			
Reset ratio	Typically 0.96			
Retardation time	<30 ms			
Operate time accuracy in definite time mode	±1.0% of the set value or ±20 ms			
Operate time accuracy in inverse time mode	±5.0% of the theoretical value or ±20 ms ³⁾			
Suppression of harmonics	RMS: No suppression DFT: -50 dB at f = n × f _n , where n = 2, 3, 4, 5, ... Peak-to-Peak: No suppression			

1) *Measurement mode* = default (depends on stage), current before fault = 0.0 × I_n, f_n = 50 Hz, earth-fault current with nominal frequency injected from random phase angle, results based on statistical distribution of 1000 measurements

2) Includes the delay of the signal output contact

3) Maximum *Start value* = 2.5 × I_n, *Start value* multiples in range of 1.5...20

Table 36. Non-directional earth-fault protection (EFxPTOC) main settings

Parameter	Function	Value (Range)	Step
Start value	EFLPTOC	$0.010 \dots 5.000 \times I_n$	0.005
	EFHPTOC	$0.10 \dots 40.00 \times I_n$	0.01
	EFIPTOC	$1.00 \dots 40.00 \times I_n$	0.01
Time multiplier	EFLPTOC	0.05...15.00	0.01
	EFHPTOC	0.05...15.00	0.01
Operate delay time	EFLPTOC	40...200000 ms	10
	EFHPTOC	40...200000 ms	10
	EFIPTOC	20...200000 ms	10
Operating curve type ¹⁾	EFLPTOC	Definite or inverse time Curve type: 1, 2, 3, 4, 5, 6, 7, 8, 9, 10, 11, 12, 13, 14, 15, 17, 18, 19	
	EFHPTOC	Definite or inverse time Curve type: 1, 3, 5, 9, 10, 12, 15, 17	
	EFIPTOC	Definite time	

1) For further reference, see Operation characteristics table

Table 37. Directional earth-fault protection (DEFxPDEF)

Characteristic	Value			
Operation accuracy	DEFLPDEF	Depending on the frequency of the measured current: $f_n \pm 2$ Hz		
	DEFHPDEF	Current: $\pm 1.5\%$ of the set value or $\pm 0.002 \times I_n$ Voltage $\pm 1.5\%$ of the set value or $\pm 0.002 \times U_n$ Phase angle: $\pm 2^\circ$		
Start time ¹⁾²⁾	DEFHPDEF	Current: $\pm 1.5\%$ of the set value or $\pm 0.002 \times I_n$ (at currents in the range of $0.1 \dots 10 \times I_n$) $\pm 5.0\%$ of the set value (at currents in the range of $10 \dots 40 \times I_n$) Voltage: $\pm 1.5\%$ of the set value or $\pm 0.002 \times U_n$ Phase angle: $\pm 2^\circ$		
	DEFLPDEF $I_{\text{Fault}} = 2 \times \text{set Start value}$	Minimum	Typical	Maximum
Reset time	DEFHPDEF	42 ms	46 ms	49 ms
Reset ratio	DEFLPDEF	58 ms	62 ms	66 ms
Retardation time	DEFHPDEF	Typically 40 ms		
Operate time accuracy in definite time mode	DEFLPDEF	Typically 0.96		
Operate time accuracy in inverse time mode		<30 ms		
Suppression of harmonics		$\pm 1.0\%$ of the set value or ± 20 ms $\pm 5.0\%$ of the theoretical value or ± 20 ms ³⁾		
		RMS: No suppression DFT: -50 dB at $f = n \times f_n$, where $n = 2, 3, 4, 5, \dots$ Peak-to-Peak: No suppression		

1) Set *Operate delay time* = 0.06 s, *Operate curve type* = IEC definite time, *Measurement mode* = default (depends on stage), current before fault = $0.0 \times I_n$, $f_n = 50$ Hz, earth-fault current with nominal frequency injected from random phase angle, results based on statistical distribution of 1000 measurements

2) Includes the delay of the signal output contact

3) Maximum *Start value* = $2.5 \times I_n$, *Start value* multiples in range of 1.5...20

Table 38. Directional earth-fault protection (DEFxPDEF) main settings

Parameter	Function	Value (Range)	Step
Start value	DEFLPDEF	$0.010...5.000 \times I_n$	0.005
	DEFHPDEF	$0.10...40.00 \times I_n$	0.01
Directional mode	DEFxPDEF	1 = Non-directional 2 = Forward 3 = Reverse	-
Time multiplier	DEFLPDEF	0.05...15.00	0.01
	DEFHPDEF	0.05...15.00	0.01
Operate delay time	DEFLPDEF	60...200000 ms	10
	DEFHPDEF	40...200000 ms	10
Operating curve type ¹⁾	DEFLPDEF	Definite or inverse time Curve type: 1, 2, 3, 4, 5, 6, 7, 8, 9, 10, 11, 12, 13, 14, 15, 17, 18, 19	
	DEFHPDEF	Definite or inverse time Curve type: 1, 3, 5, 15, 17	
Operation mode	DEFxPDEF	1 = Phase angle 2 = $I_o \sin$ 3 = $I_o \cos$ 4 = Phase angle 80 5 = Phase angle 88	-

1) For further reference, refer to the Operating characteristics table

Table 39. Admittance-based earth-fault protection (EFPADM)

Characteristic	Value						
Operation accuracy ¹⁾	At the frequency $f = f_n$ $\pm 1.0\%$ or ± 0.01 mS (In range of 0.5...100 mS)						
Start time ²⁾	<table border="1"> <thead> <tr> <th>Minimum</th> <th>Typical</th> <th>Maximum</th> </tr> </thead> <tbody> <tr> <td>56 ms</td> <td>60 ms</td> <td>64 ms</td> </tr> </tbody> </table>	Minimum	Typical	Maximum	56 ms	60 ms	64 ms
Minimum	Typical	Maximum					
56 ms	60 ms	64 ms					
Reset time	40 ms						
Operate time accuracy	$\pm 1.0\%$ of the set value of ± 20 ms						
Suppression of harmonics	-50 dB at $f = n \times f_n$, where $n = 2, 3, 4, 5, \dots$						

1) $U_o = 1.0 \times U_n$

2) Includes the delay of the signal output contact, results based on statistical distribution of 1000 measurements

Table 40. Admittance-based earth-fault protection (EFPADM) main settings

Parameter	Function	Value (Range)	Step
Voltage start value	EFPADM	0.01...2.00 × U _n	0.01
Directional mode	EFPADM	1 = Non-directional 2 = Forward 3 = Reverse	-
Operation mode	EFPADM	1 = Yo 2 = Go 3 = Bo 4 = Yo, Go 5 = Yo, Bo 6 = Go, Bo 7 = Yo, Go, Bo	-
Operate delay time	EFPADM	60...200000 ms	10
Circle radius	EFPADM	0.05...500.00 mS	0.01
Circle conductance	EFPADM	-500.00...500.00 mS	0.01
Circle susceptance	EFPADM	-500.00...500.00 mS	0.01
Conductance forward	EFPADM	-500.00...500.00 mS	0.01
Conductance reverse	EFPADM	-500.00...500.00 mS	0.01
Susceptance forward	EFPADM	-500.00...500.00 mS	0.01
Susceptance reverse	EFPADM	-500.00...500.00 mS	0.01
Conductance tilt Ang	EFPADM	-30...30°	1
Susceptance tilt Ang	EFPADM	-30...30°	1

Table 41. Wattmetric-based earth-fault protection (WPWDE)

Characteristic	Value
Operation accuracy	Depending on the frequency of the measured current: f _n ±2 Hz Current and voltage: ±1.5% of the set value or ±0.002 × I _n Power: ±3% of the set value or ±0.002 × P _n
Start time ¹⁾²⁾	Typically 63 ms
Reset time	Typically 40 ms
Reset ratio	Typically 0.96
Operate time accuracy in definite time mode	±1.0% of the set value or ±20 ms
Operate time accuracy in IDMT mode	±5.0% of the set value or ±20 ms
Suppression of harmonics	-50 dB at f = n × f _n , where n = 2,3,4,5,...

1) I_o varied during the test, U_o = 1.0 × U_n = phase to earth voltage during earth fault in compensated or un-earthed network, the residual power value before fault = 0.0 pu, f_n = 50 Hz, results based on statistical distribution of 1000 measurements

2) Includes the delay of the signal output contact

Table 42. Wattmetric-based earth-fault protection (WPWDE) main settings

Parameter	Function	Value (Range)	Step
Directional mode	WPWDE	2 = Forward 3 = Reverse	-
Current start value	WPWDE	$0.010...5.000 \times I_n$	0.001
Voltage start value	WPWDE	$0.010...1.000 \times U_n$	0.001
Power start value	WPWDE	$0.003...1.000 \times P_n$	0.001
Reference power	WPWDE	$0.050...1.000 \times P_n$	0.001
Characteristic angle	WPWDE	$-179...180^\circ$	1
Time multiplier	WPWDE	0.05...2.00	0.01
Operating curve type ¹⁾	WPWDE	Definite or inverse time Curve type: 5, 15, 20	
Operate delay time	WPWDE	60...200000 ms	10
Min operate current	WPWDE	$0.010...1.000 \times I_n$	0.001
Min operate voltage	WPWDE	$0.01...1.00 \times U_n$	0.01

1) For further reference, refer to the Operating characteristics table

Table 43. Multifrequency admittance-based earth-fault protection (MFADPSDE)

Characteristic	Value
Operation accuracy	Depending on the frequency of the measured voltage: $f_n \pm 2$ Hz $\pm 1.5\%$ of the set value or $\pm 0.002 \times U_n$
Start time ¹⁾	Typically 35 ms
Reset time	Typically 40 ms
Operate time accuracy	$\pm 1.0\%$ of the set value or ± 20 ms

1) Includes the delay of the signal output contact, results based on statistical distribution of 1000 measurements

Table 44. Multifrequency admittance-based earth-fault protection (MFADPSDE) main settings

Parameter	Function	Value (Range)	Step
Directional mode	MFADPSDE	2 = Forward 3 = Reverse	-
Voltage start value	MFADPSDE	$0.01...1.00 \times U_n$	0.01
Operate delay time	MFADPSDE	60...1200000	10
Operating quantity	MFADPSDE	1 = Adaptive 2 = Amplitude	-
Min operate current	MFADPSDE	$0.005...5.000 \times I_n$	0.001
Operation mode	MFADPSDE	1 = Intermittent EF 3 = General EF 4 = Alarming EF	-
Peak counter limit	MFADPSDE	2...20	1

Table 45. Transient/intermittent earth-fault protection (INTRPTEF)

Characteristic	Value
Operation accuracy (U _o criteria with transient protection)	Depending on the frequency of the measured current: $f_n \pm 2$ Hz $\pm 1.5\%$ of the set value or $\pm 0.002 \times U_o$
Operate time accuracy	$\pm 1.0\%$ of the set value or ± 20 ms
Suppression of harmonics	DFT: -50 dB at $f = n \times f_n$, where $n = 2, 3, 4, 5$

Table 46. Transient/intermittent earth-fault protection (INTRPTEF) main settings

Parameter	Function	Value (Range)	Step
Directional mode	INTRPTEF	1 = Non-directional 2 = Forward 3 = Reverse	-
Operate delay time	INTRPTEF	40...1200000 ms	10
Voltage start value	INTRPTEF	$0.05...0.50 \times U_n$	0.01
Operation mode	INTRPTEF	1 = Intermittent EF 2 = Transient EF	-
Peak counter limit	INTRPTEF	2...20	-
Min operate current	INTRPTEF	$0.01...1.00 \times I_n$	0.01

Table 47. Harmonics-based earth-fault protection (HAEFPTOC)

Characteristic	Value
Operation accuracy	Depending on the frequency of the measured current: $f_n \pm 2$ Hz $\pm 5\%$ of the set value or $\pm 0.004 \times I_n$
Start time ¹⁾²⁾	Typically 77 ms
Reset time	Typically 40 ms
Reset ratio	Typically 0.96
Operate time accuracy in definite time mode	$\pm 1.0\%$ of the set value or ± 20 ms
Operate time accuracy in IDMT mode ³⁾	$\pm 5.0\%$ of the set value or ± 20 ms
Suppression of harmonics	-50 dB at $f = f_n$ -3 dB at $f = 13 \times f_n$

1) Fundamental frequency current = $1.0 \times I_n$, harmonics current before fault = $0.0 \times I_n$, harmonics fault current $2.0 \times \text{Start value}$, results based on statistical distribution of 1000 measurements

2) Includes the delay of the signal output contact

3) Maximum *Start value* = $2.5 \times I_n$, *Start value* multiples in range of 2...20

Table 48. Harmonics-based earth-fault protection (HAEFPTOC) main settings

Parameter	Function	Value (Range)	Step
Start value	HAEFPTOC	$0.05...5.00 \times I_n$	0.01
Time multiplier	HAEFPTOC	0.05...15.00	0.01
Operate delay time	HAEFPTOC	100...200000 ms	10
Operating curve type ¹⁾	HAEFPTOC	Definite or inverse time Curve type: 1, 2, 3, 4, 5, 6, 7, 8, 9, 10, 11, 12, 13, 14, 15, 17, 18, 19	
Minimum operate time	HAEFPTOC	100...200000 ms	10

1) For further reference, see Operation characteristics table

Table 49. Negative-sequence overcurrent protection (NSPTOC)

Characteristic	Value												
Operation accuracy	Depending on the frequency of the measured current: $f_n \pm 2$ Hz $\pm 1.5\%$ of the set value or $\pm 0.002 \times I_n$												
Start time ¹⁾²⁾	<table border="1"> <thead> <tr> <th></th> <th>Minimum</th> <th>Typical</th> <th>Maximum</th> </tr> </thead> <tbody> <tr> <td>$I_{Fault} = 2 \times \text{set Start value}$</td> <td>23 ms</td> <td>26 ms</td> <td>28 ms</td> </tr> <tr> <td>$I_{Fault} = 10 \times \text{set Start value}$</td> <td>15 ms</td> <td>18 ms</td> <td>20 ms</td> </tr> </tbody> </table>		Minimum	Typical	Maximum	$I_{Fault} = 2 \times \text{set Start value}$	23 ms	26 ms	28 ms	$I_{Fault} = 10 \times \text{set Start value}$	15 ms	18 ms	20 ms
	Minimum	Typical	Maximum										
$I_{Fault} = 2 \times \text{set Start value}$	23 ms	26 ms	28 ms										
$I_{Fault} = 10 \times \text{set Start value}$	15 ms	18 ms	20 ms										
Reset time	Typically 40 ms												
Reset ratio	Typically 0.96												
Retardation time	<35 ms												
Operate time accuracy in definite time mode	$\pm 1.0\%$ of the set value or ± 20 ms												
Operate time accuracy in inverse time mode	$\pm 5.0\%$ of the theoretical value or ± 20 ms ³⁾												
Suppression of harmonics	DFT: -50 dB at $f = n \times f_n$, where $n = 2, 3, 4, 5, \dots$												

1) Negative sequence current before fault = 0.0, $f_n = 50$ Hz, results based on statistical distribution of 1000 measurements

2) Includes the delay of the signal output contact

3) Maximum *Start value* = $2.5 \times I_n$, *Start value* multiples in range of 1.5...20

Table 50. Negative-sequence overcurrent protection (NSPTOC) main settings

Parameter	Function	Value (Range)	Step
Start value	NSPTOC	$0.01 \dots 5.00 \times I_n$	0.01
Time multiplier	NSPTOC	0.05...15.00	0.01
Operate delay time	NSPTOC	40...200000 ms	10
Operating curve type ¹⁾	NSPTOC	Definite or inverse time Curve type: 1, 2, 3, 4, 5, 6, 7, 8, 9, 10, 11, 12, 13, 14, 15, 17, 18, 19	

1) For further reference, see Operation characteristics table

Table 51. Phase discontinuity protection (PDNSPTOC)

Characteristic	Value
Operation accuracy	Depending on the frequency of the measured current: $f_n \pm 2$ Hz $\pm 2\%$ of the set value
Start time	<70 ms
Reset time	Typically 40 ms
Reset ratio	Typically 0.96
Retardation time	<35 ms
Operate time accuracy in definite time mode	$\pm 1.0\%$ of the set value or ± 20 ms
Suppression of harmonics	DFT: -50 dB at $f = n \times f_n$, where $n = 2, 3, 4, 5, \dots$

Table 52. Phase discontinuity protection (PDNSPTOC) main settings

Parameter	Function	Value (Range)	Step
Start value	PDNSPTOC	10...100%	1
Operate delay time	PDNSPTOC	100...30000 ms	1
Min phase current	PDNSPTOC	$0.05 \dots 0.30 \times I_n$	0.01

Table 53. Residual overvoltage protection (ROVPTOV)

Characteristic	Value		
Operation accuracy	Depending on the frequency of the measured voltage: $f_n \pm 2$ Hz $\pm 1.5\%$ of the set value or $\pm 0.002 \times U_n$		
Start time ¹⁾²⁾	Minimum	Typical	Maximum
	48 ms	51 ms	54 ms
	$U_{Fault} = 2 \times \text{set Start value}$		
Reset time	Typically 40 ms		
Reset ratio	Typically 0.96		
Retardation time	<35 ms		
Operate time accuracy in definite time mode	$\pm 1.0\%$ of the set value or ± 20 ms		
Suppression of harmonics	DFT: -50 dB at $f = n \times f_n$, where $n = 2, 3, 4, 5, \dots$		

1) Residual voltage before fault = $0.0 \times U_n$, $f_n = 50$ Hz, residual voltage with nominal frequency injected from random phase angle, results based on statistical distribution of 1000 measurements

2) Includes the delay of the signal output contact

Table 54. Residual overvoltage protection (ROVPTOV) main settings

Parameter	Function	Value (Range)	Step
Start value	ROVPTOV	$0.010 \dots 1.000 \times U_n$	0.001
Operate delay time	ROVPTOV	40...300000 ms	1

Table 55. Three-phase undervoltage protection (PHPTUV)

Characteristic	Value		
Operation accuracy	Depending on the frequency of the voltage measured: $f_n \pm 2$ Hz $\pm 1.5\%$ of the set value or $\pm 0.002 \times U_n$		
Start time ¹⁾²⁾	Minimum	Typical	Maximum
	62 ms	66 ms	70 ms
	$U_{Fault} = 0.9 \times \text{set Start value}$		
Reset time	Typically 40 ms		
Reset ratio	Depends on the set <i>Relative hysteresis</i>		
Retardation time	<35 ms		
Operate time accuracy in definite time mode	$\pm 1.0\%$ of the set value or ± 20 ms		
Operate time accuracy in inverse time mode	$\pm 5.0\%$ of the theoretical value or ± 20 ms ³⁾		
Suppression of harmonics	DFT: -50 dB at $f = n \times f_n$, where $n = 2, 3, 4, 5, \dots$		

1) *Start value* = $1.0 \times U_n$, Voltage before fault = $1.1 \times U_n$, $f_n = 50$ Hz, undervoltage in one phase-to-phase with nominal frequency injected from random phase angle, results based on statistical distribution of 1000 measurements

2) Includes the delay of the signal output contact

3) Minimum *Start value* = 0.50, *Start value* multiples in range of 0.90...0.20

Table 56. Three-phase undervoltage protection (PHPTUV) main settings

Parameter	Function	Value (Range)	Step
Start value	PHPTUV	$0.05...1.20 \times U_n$	0.01
Time multiplier	PHPTUV	0.05...15.00	0.01
Operate delay time	PHPTUV	60...300000 ms	10
Operating curve type ¹⁾	PHPTUV	Definite or inverse time Curve type: 5, 15, 21, 22, 23	

1) For further reference, see Operation characteristics table

Table 57. Single-phase undervoltage protection (PHAPTUV)

Characteristic	Value			
Operation accuracy	Depending on the frequency of the measured voltage: $f_n \pm 2$ Hz $\pm 1.5\%$ of the set value or $\pm 0.002 \times U_n$			
Start time ¹⁾²⁾	$U_{Fault} = 0.9 \times \text{set Start value}$	Minimum 64 ms	Typical 68 ms	Maximum 71 ms
Reset time	Typically 40 ms			
Reset ratio	Depends on the set <i>Relative hysteresis</i>			
Retardation time	<35 ms			
Operate time accuracy in definite time mode	$\pm 1.0\%$ of the set value or ± 20 ms			
Operate time accuracy in inverse time mode	$\pm 5.0\%$ of the theoretical value or ± 20 ms ³⁾			
Suppression of harmonics	DFT: -50 dB at $f = n \times f_n$, where $n = 2, 3, 4, 5, \dots$			

1) *Start value* = $1.0 \times U_n$, voltage before fault = $1.1 \times U_n$, $f_n = 50$ Hz, undervoltage in one phase-to-phase with nominal frequency injected from random phase angle, results based on statistical distribution of 1000 measurements

2) Includes the delay of the signal output contact

3) Maximum *Start value* = $0.50 \times U_n$, *Start value* multiples in range of 0.90...0.20

Table 58. Single-phase undervoltage protection (PHAPTUV) main settings

Parameter	Function	Value (Range)	Step
Start value	PHAPTUV	$0.05...1.20 \times U_n$	0.01
Time multiplier	PHAPTUV	0.05...15.00	0.01
Operate delay time	PHAPTUV	60...300000 ms	10
Operating curve type ¹⁾	PHAPTUV	Definite or inverse time Curve type: 5, 15, 21, 22, 23	

1) For further reference, see Operation characteristics table

Table 59. Three-phase overvoltage protection (PHPTOV)

Characteristic	Value			
Operation accuracy	Depending on the frequency of the measured voltage: $f_n \pm 2$ Hz $\pm 1.5\%$ of the set value or $\pm 0.002 \times U_n$			
Start time ¹⁾²⁾	$U_{Fault} = 1.1 \times \text{set Start value}$	Minimum	Typical	Maximum
		23 ms	27 ms	31 ms
Reset time	Typically 40 ms			
Reset ratio	Depends on the set <i>Relative hysteresis</i>			
Retardation time	<35 ms			
Operate time accuracy in definite time mode	$\pm 1.0\%$ of the set value or ± 20 ms			
Operate time accuracy in inverse time mode	$\pm 5.0\%$ of the theoretical value or ± 20 ms ³⁾			
Suppression of harmonics	DFT: -50 dB at $f = n \times f_n$, where $n = 2, 3, 4, 5, \dots$			

- 1) *Start value* = $1.0 \times U_n$, Voltage before fault = $0.9 \times U_n$, $f_n = 50$ Hz, overvoltage in one phase-to-phase with nominal frequency injected from random phase angle, results based on statistical distribution of 1000 measurements
2) Includes the delay of the signal output contact
3) Maximum *Start value* = $1.20 \times U_n$, *Start value* multiples in range of 1.10...2.00

Table 60. Three-phase overvoltage protection (PHPTOV) main settings

Parameter	Function	Value (Range)	Step
Start value	PHPTOV	$0.05 \dots 1.60 \times U_n$	0.01
Time multiplier	PHPTOV	0.05...15.00	0.01
Operate delay time	PHPTOV	40...300000 ms	10
Operating curve type ¹⁾	PHPTOV	Definite or inverse time Curve type: 5, 15, 17, 18, 19, 20	

- 1) For further reference, see Operation characteristics table

Table 61. Single-phase overvoltage protection (PHAPTOV)

Characteristic	Value			
Operation accuracy	Depending on the frequency of the measured voltage: $f_n \pm 2$ Hz $\pm 1.5\%$ of the set value or $\pm 0.002 \times U_n$			
Start time ¹⁾²⁾	$U_{Fault} = 1.1 \times \text{set Start value}$	Minimum	Typical	Maximum
		25 ms	28 ms	32 ms
Reset time	Typically 40 ms			
Reset ratio	Depends on the set <i>Relative hysteresis</i>			
Retardation time	<35 ms			
Operate time accuracy in definite time mode	$\pm 1.0\%$ of the set value or ± 20 ms			
Operate time accuracy in inverse time mode	$\pm 5.0\%$ of the theoretical value or ± 20 ms ³⁾			
Suppression of harmonics	DFT: -50 dB at $f = n \times f_n$, where $n = 2, 3, 4, 5, \dots$			

- 1) *Start value* = $1.0 \times U_n$, voltage before fault = $0.9 \times U_n$, $f_n = 50$ Hz, overvoltage in one phase-to-phase with nominal frequency injected from random phase angle, results based on statistical distribution of 1000 measurements
2) Includes the delay of the signal output contact
3) Maximum *Start value* = $1.20 \times U_n$, *Start value* multiples in range of 1.10...2.00

Table 62. Single-phase overvoltage protection (PHAPTOV) main settings

Parameter	Function	Value (Range)	Step
Start value	PHAPTOV	$0.05 \dots 1.60 \times U_n$	0.01
Time multiplier	PHAPTOV	0.05...15.00	0.01
Operate delay time	PHAPTOV	40...300000 ms	10
Operating curve type ¹⁾	PHAPTOV	Definite or inverse time Curve type: 5, 15, 17, 18, 19, 20	

1) For further reference, see Operation characteristics table

Table 63. Positive-sequence undervoltage protection (PSPTUV)

Characteristic	Value			
Operation accuracy	Depending on the frequency of the measured voltage: $f_n \pm 2$ Hz $\pm 1.5\%$ of the set value or $\pm 0.002 \times U_n$			
Start time ¹⁾²⁾		Minimum	Typical	Maximum
	$U_{Fault} = 0.99 \times \text{set Start value}$	52 ms	55 ms	58 ms
	$U_{Fault} = 0.9 \times \text{set Start value}$	44 ms	47 ms	50 ms
Reset time	Typically 40 ms			
Reset ratio	Depends on the set <i>Relative hysteresis</i>			
Retardation time	<35 ms			
Operate time accuracy in definite time mode	$\pm 1.0\%$ of the set value or ± 20 ms			
Suppression of harmonics	DFT: -50 dB at $f = n \times f_n$, where $n = 2, 3, 4, 5, \dots$			

1) *Start value* = $1.0 \times U_n$, positive-sequence voltage before fault = $1.1 \times U_n$, $f_n = 50$ Hz, positive sequence undervoltage with nominal frequency injected from random phase angle, results based on statistical distribution of 1000 measurements

2) Includes the delay of the signal output contact

Table 64. Positive-sequence undervoltage protection (PSPTUV) main settings

Parameter	Function	Value (Range)	Step
Start value	PSPTUV	$0.010 \dots 1.200 \times U_n$	0.001
Operate delay time	PSPTUV	40...120000 ms	10
Voltage block value	PSPTUV	$0.01 \dots 1.00 \times U_n$	0.01

Table 65. Negative-sequence overvoltage protection (NSPTOV)

Characteristic		Value		
Operation accuracy		Depending on the frequency of the voltage measured: $f_n \pm 2$ Hz $\pm 1.5\%$ of the set value or $\pm 0.002 \times U_n$		
Start time ¹⁾²⁾	$U_{Fault} = 1.1 \times \text{set Start value}$ $U_{Fault} = 2.0 \times \text{set Start value}$	Minimum	Typical	Maximum
		33 ms 24 ms	35 ms 26 ms	37 ms 28 ms
Reset time		Typically 40 ms		
Reset ratio		Typically 0.96		
Retardation time		<35 ms		
Operate time accuracy in definite time mode		$\pm 1.0\%$ of the set value or ± 20 ms		
Suppression of harmonics		DFT: -50 dB at $f = n \times f_n$, where $n = 2, 3, 4, 5, \dots$		

1) Negative-sequence voltage before fault = $0.0 \times U_n$, $f_n = 50$ Hz, negative-sequence overvoltage with nominal frequency injected from random phase angle, results based on statistical distribution of 1000 measurements

2) Includes the delay of the signal output contact

Table 66. Negative-sequence overvoltage protection (NSPTOV) main settings

Parameter	Function	Value (Range)	Step
Start value	NSPTOV	$0.010 \dots 1.000 \times U_n$	0.001
Operate delay time	NSPTOV	40...120000 ms	1

Table 67. Frequency protection (FRPFRQ)

Characteristic		Value
Operation accuracy	$f > / f <$	± 5 mHz
	df/dt	± 50 mHz/s (in range $ df/dt < 5$ Hz/s) $\pm 2.0\%$ of the set value (in range $5 \text{ Hz/s} < df/dt < 15 \text{ Hz/s}$)
Start time	$f > / f <$	<80 ms
	df/dt	<120 ms
Reset time		<150 ms
Operate time accuracy		$\pm 1.0\%$ of the set value or ± 30 ms

Table 68. Frequency protection (FRPFRQ) main settings

Parameter	Function	Value (Range)	Step
Operation mode	FRPFRQ	1 = Freq< 2 = Freq> 3 = df/dt 4 = Freq< + df/dt 5 = Freq> + df/dt 6 = Freq< OR df/dt 7 = Freq> OR df/dt	-
Start value Freq>	FRPFRQ	0.9000...1.2000 × f _n	0.0001
Start value Freq<	FRPFRQ	0.8000...1.1000 × f _n	0.0001
Start value df/dt	FRPFRQ	-0.2000...0.2000 × f _n /s	0.0025
Operate Tm Freq	FRPFRQ	80...200000 ms	10
Operate Tm df/dt	FRPFRQ	120...200000 ms	10

Table 69. Three-phase thermal protection for feeders, cables and distribution transformers (T1PTTR)

Characteristic	Value
Operation accuracy	Depending on the frequency of the measured current: f _n ±2 Hz Current measurement: ±1.5% of the set value or ±0.002 × I _n (at currents in the range of 0.01...4.00 × I _n)
Operate time accuracy ¹⁾	±2.0% of the theoretical value or ±0.50 s

1) Overload current > 1.2 × Operate level temperature

Table 70. Three-phase thermal protection for feeders, cables and distribution transformers (T1PTTR) main settings

Parameter	Function	Value (Range)	Step
Env temperature Set	T1PTTR	-50...100°C	1
Current reference	T1PTTR	0.05...4.00 × I _n	0.01
Temperature rise	T1PTTR	0.0...200.0°C	0.1
Time constant	T1PTTR	60...60000 s	1
Maximum temperature	T1PTTR	20.0...200.0°C	0.1
Alarm value	T1PTTR	20.0...150.0°C	0.1
Reclose temperature	T1PTTR	20.0...150.0°C	0.1
Current multiplier	T1PTTR	1...5	1
Initial temperature	T1PTTR	-50.0...100.0°C	0.1

Table 71. Loss of phase, undercurrent (PHPTUC)

Characteristic	Value
Operation accuracy	Depending on the frequency of the current measured: $f_n \pm 2$ Hz $\pm 1.5\%$ of the set value or $\pm 0.002 \times I_n$
Start time	Typically <55 ms
Reset time	<40 ms
Reset ratio	Typically 1.04
Retardation time	<35 ms
Operate time accuracy in definite time mode	mode $\pm 1.0\%$ of the set value or ± 20 ms

Table 72. Phase undercurrent protection (PHPTUC) main settings

Parameter	Function	Value (Range)	Step
Current block value	PHPTUC	$0.00 \dots 0.50 \times I_n$	0.01
Start value	PHPTUC	$0.01 \dots 1.00 \times I_n$	0.01
Operate delay time	PHPTUC	50...200000 ms	10

Table 73. Circuit breaker failure protection (CCBRBRF)

Characteristic	Value
Operation accuracy	Depending on the frequency of the measured current: $f_n \pm 2$ Hz $\pm 1.5\%$ of the set value or $\pm 0.002 \times I_n$
Operate time accuracy	$\pm 1.0\%$ of the set value or ± 20 ms
Reset time ¹⁾	Typically 40 ms
Retardation time	<20 ms

1) Trip pulse time defines the minimum pulse length

Table 74. Circuit breaker failure protection (CCBRBRF) main settings

Parameter	Function	Value (Range)	Step
Current value	CCBRBRF	$0.05 \dots 2.00 \times I_n$	0.01
Current value Res	CCBRBRF	$0.05 \dots 2.00 \times I_n$	0.01
CB failure mode	CCBRBRF	1 = Current 2 = Breaker status 3 = Both	-
CB fail retrip mode	CCBRBRF	1 = Off 2 = Without check 3 = Current check	-
Retrip time	CCBRBRF	0...60000 ms	10
CB failure delay	CCBRBRF	0...60000 ms	10
CB fault delay	CCBRBRF	0...60000 ms	10

Table 75. Three-phase inrush detector (INRPHAR)

Characteristic	Value
Operation accuracy	At the frequency $f = f_n$ Current measurement: $\pm 1.5\%$ of the set value or $\pm 0.002 \times I_n$ Ratio I_{2f}/I_{1f} measurement: $\pm 5.0\%$ of the set value
Reset time	+35 ms / -0 ms
Reset ratio	Typically 0.96
Operate time accuracy	+35 ms / -0 ms

Table 76. Three-phase inrush detector (INRPHAR) main settings

Parameter	Function	Value (Range)	Step
Start value	INRPHAR	5...100%	1
Operate delay time	INRPHAR	20...60000 ms	1

Table 77. Arc protection (ARCSARC)

Characteristic	Value												
Operation accuracy	$\pm 3\%$ of the set value or $\pm 0.01 \times I_n$												
Operate time	<table border="1"> <thead> <tr> <th></th> <th>Minimum</th> <th>Typical</th> <th>Maximum</th> </tr> </thead> <tbody> <tr> <td><i>Operation mode</i> = "Light +current"¹⁾²⁾</td> <td>9 ms³⁾ 4 ms⁴⁾</td> <td>12 ms³⁾ 6 ms⁴⁾</td> <td>15 ms³⁾ 9 ms⁴⁾</td> </tr> <tr> <td><i>Operation mode</i> = "Light only"²⁾</td> <td>9 ms³⁾ 4 ms⁴⁾</td> <td>10 ms³⁾ 6 ms⁴⁾</td> <td>12 ms³⁾ 7 ms⁴⁾</td> </tr> </tbody> </table>		Minimum	Typical	Maximum	<i>Operation mode</i> = "Light +current" ¹⁾²⁾	9 ms ³⁾ 4 ms ⁴⁾	12 ms ³⁾ 6 ms ⁴⁾	15 ms ³⁾ 9 ms ⁴⁾	<i>Operation mode</i> = "Light only" ²⁾	9 ms ³⁾ 4 ms ⁴⁾	10 ms ³⁾ 6 ms ⁴⁾	12 ms ³⁾ 7 ms ⁴⁾
	Minimum	Typical	Maximum										
<i>Operation mode</i> = "Light +current" ¹⁾²⁾	9 ms ³⁾ 4 ms ⁴⁾	12 ms ³⁾ 6 ms ⁴⁾	15 ms ³⁾ 9 ms ⁴⁾										
<i>Operation mode</i> = "Light only" ²⁾	9 ms ³⁾ 4 ms ⁴⁾	10 ms ³⁾ 6 ms ⁴⁾	12 ms ³⁾ 7 ms ⁴⁾										
Reset time	Typically 40 ms ³⁾ <55 ms ⁴⁾												
Reset ratio	Typically 0.96												

1) *Phase start value* = $1.0 \times I_n$, current before fault = $2.0 \times$ set *Phase start value*, $f_n = 50$ Hz, fault with nominal frequency, results based on statistical distribution of 200 measurements

2) Includes the delay of the heavy-duty output contact

3) Normal power output

4) High-speed output

Table 78. Arc protection (ARCSARC) main settings

Parameter	Function	Value (Range)	Step
Phase start value	ARCSARC	$0.50...40.00 \times I_n$	0.01
Ground start value	ARCSARC	$0.05...8.00 \times I_n$	0.01
Operation mode	ARCSARC	1 = Light+current 2 = Light only 3 = BI controlled	-

Table 79. High-impedance fault detection (PHIZ) main settings

Parameter	Function	Value (Range)	Step
Security Level	PHIZ	1...10	1
System type	PHIZ	1 = Grounded 2 = Ungrounded	-

Table 80. Load-shedding and restoration (LSHDPFRQ)

Characteristic		Value
Operation accuracy	f<	±10 mHz
	df/dt	±100 mHz/s (in range df/dt < 5 Hz/s) ± 2.0% of the set value (in range 5 Hz/s < df/dt < 15 Hz/s)
Start time	f<	<80 ms
	df/dt	<120 ms
Reset time		<150 ms
Operate time accuracy		±1.0% of the set value or ±30 ms

Table 81. Load-shedding and restoration (LSHDPFRQ) main settings

Parameter	Function	Value (Range)	Step
Load shed mode	LSHDPFRQ	1 = Freq< 6 = Freq< OR df/dt 8 = Freq< AND df/dt	-
Restore mode	LSHDPFRQ	1 = Disabled 2 = Auto 3 = Manual	-
Start value Freq	LSHDPFRQ	0.800...1.200 × f _n	0.001
Start value df/dt	LSHDPFRQ	-0.200...-0.005 × f _n	0.005
Operate Tm Freq	LSHDPFRQ	80...200000 ms	10
Operate Tm df/dt	LSHDPFRQ	120...200000 ms	10
Restore start Val	LSHDPFRQ	0.800...1.200 × f _n	0.001
Restore delay time	LSHDPFRQ	80...200000 ms	10

Table 82. Multipurpose protection (MAPGAPC)

Characteristic	Value
Operation accuracy	±1.0% of the set value or ±20 ms

Table 83. Multipurpose protection (MAPGAPC) main settings

Parameter	Function	Value (Range)	Step
Start value	MAPGAPC	-10000.0...10000.0	0.1
Operate delay time	MAPGAPC	0...200000 ms	100
Operation mode	MAPGAPC	1 = Over 2 = Under	-

Table 84. Automatic switch-onto-fault (CVPSOF)

Characteristic	Value
Operation accuracy	Depending on the frequency of the voltage measured: f _n ±2Hz Current: ±1.5% of the set value or ±0.002 × I _n Voltage: ±1.5% of the set value or ±0.002 × U _n
Operate time accuracy	±1.0% of the set value or ±20 ms
Suppression of harmonics	DFT: -50 dB at f = n × f _n , where n = 2, 3, 4, 5,...

Table 85. Automatic switch-onto-fault logic (CVPSOF) main settings

Parameter	Function	Value (Range)	Step
SOTF reset time	CVPSOF	0...60000 ms	10

Table 86. Voltage vector shift protection (VVSPAM)

Characteristic	Value
Operation accuracy	Depending on the frequency of the measured voltage: $f_n \pm 1$ Hz $\pm 1^\circ$
Operate time ¹⁾²⁾	Typically 53 ms

1) $f_n = 50$ Hz, results based on statistical distribution of 1000 measurements

2) Includes the delay of the signal output contact

Table 87. Voltage vector shift protection (VVSPAM) main settings

Parameter	Function	Value (Range)	Step
Start value	VVSPAM	2.0...30.0°	0.1
Over Volt Blk value	VVSPAM	0.40...1.50 × U_n	0.01
Under Volt Blk value	VVSPAM	0.15...1.00 × U_n	0.01
Phase supervision	VVSPAM	7 = Ph A + B + C 8 = Pos sequence	-

Table 88. Directional reactive power undervoltage protection (DQPTUV)

Characteristic	Value
Operation accuracy	Depending on the frequency of the measured current and voltage: $f_n \pm 2$ Hz Reactive power range $ PF < 0.71$ Power: $\pm 3.0\%$ or $\pm 0.002 \times Q_n$ Voltage: $\pm 1.5\%$ of the set value or $\pm 0.002 \times U_n$
Start time ¹⁾²⁾	Typically 46 ms
Reset time	<50 ms
Reset ratio	Typically 0.96
Operate time accuracy	$\pm 1.0\%$ of the set value or ± 20 ms
Suppression of harmonics	DFT: -50 dB at $f = n \times f_n$, where $n = 2, 3, 4, 5, \dots$

1) $Start\ value = 0.05 \times S_n$, reactive power before fault = $0.8 \times Start\ value$, reactive power overshoot 2 times, results based on statistical distribution of 1000 measurements

2) Includes the delay of the signal output contact

Table 89. Directional reactive power undervoltage protection (DQPTUV) main settings

Parameter	Function	Value (Range)	Step
Voltage start value	DQPTUV	0.20...1.20 × U _n	0.01
Operate delay time	DQPTUV	100...300000 ms	10
Min reactive power	DQPTUV	0.01...0.50 × S _n	0.01
Min Ps Seq current	DQPTUV	0.02...0.20 × I _n	0.01
Pwr sector reduction	DQPTUV	0...10°	1

Table 90. Underpower protection (DUPPDPR)

Characteristic	Value
Operation accuracy ¹⁾	Depending on the frequency of the measured current and voltage: f _n ±2 Hz Power measurement accuracy ±3% of the set value or ±0.002 × S _n Phase angle: ±2°
Start time ²⁾³⁾	Typically 45 ms
Reset time	Typically 30 ms
Reset ratio	Typically 1.04
Operate time accuracy	±1.0% of the set value of ±20 ms
Suppression of harmonics	-50 dB at f = n × f _n , where n = 2, 3, 4, 5,...

1) *Measurement mode* = "Pos Seq" (default)

2) U = U_n, f_n = 50 Hz, results based on statistical distribution of 1000 measurements

3) Includes the delay of the signal output contact

Table 91. Underpower protection (DUPPDPR) main settings

Parameter	Function	Value (Range)	Step
Start value	DUPPDPR	0.01...2.00 × S _n	0.01
Operate delay time	DUPPDPR	40...300000 ms	10
Pol reversal	DUPPDPR	0 = False 1 = True	-
Disable time	DUPPDPR	0...60000 ms	1000

Table 92. Reverse power/directional overpower protection (DOPPDPR)

Characteristic	Value
Operation accuracy ¹⁾	Depending on the frequency of the measured current and voltage: $f = f_n \pm 2 \text{ Hz}$ Power measurement accuracy $\pm 3\%$ of the set value or $\pm 0.002 \times S_n$ Phase angle: $\pm 2^\circ$
Start time ²⁾³⁾	Typically 45 ms
Reset time	Typically 30 ms
Reset ratio	Typically 0.94
Operate time accuracy	$\pm 1.0\%$ of the set value of $\pm 20 \text{ ms}$
Suppression of harmonics	-50 dB at $f = n \times f_n$, where $n = 2, 3, 4, 5, \dots$

1) *Measurement mode* = "Pos Seq" (default)

2) $U = U_n$, $f_n = 50 \text{ Hz}$, results based on statistical distribution of 1000 measurements

3) Includes the delay of the signal output contact

Table 93. Reverse power/directional overpower protection (DOPPDPR) main settings

Parameter	Function	Value (Range)	Step
Start value	DOPPDPR	$0.01 \dots 2.00 \times S_n$	0.01
Operate delay time	DOPPDPR	40...300000	10
Directional mode	DOPPDPR	2 = Forward 3 = Reverse	-
Power angle	DOPPDPR	$-90 \dots 90^\circ$	1

Table 94. Low-voltage ride-through protection (LVRTPTUV)

Characteristic	Value
Operation accuracy	Depending on the frequency of the measured voltage: $f_n \pm 2 \text{ Hz}$ $\pm 1.5\%$ of the set value or $\pm 0.002 \times U_n$
Start time ¹⁾²⁾	Typically 40 ms
Reset time	Based on maximum value of <i>Recovery time</i> setting
Operate time accuracy	$\pm 1.0\%$ of the set value or $\pm 20 \text{ ms}$
Suppression of harmonics	DFT: -50 dB at $f = n \times f_n$, where $n = 2, 3, 4, 5, \dots$

1) Tested for *Number of Start phases* = 1 out of 3, results based on statistical distribution of 1000 measurements

2) Includes the delay of the signal output contact

Table 95. Low-voltage ride-through protection (LVRTPTUV) main settings

Parameter	Function	Value (Range)	Step
Voltage start value	LVRTPTUV	0.05...1.20 × U _n	0.01
Num of start phases	LVRTPTUV	4 = Exactly 1 of 3 5 = Exactly 2 of 3 6 = Exactly 3 of 3	-
Voltage selection	LVRTPTUV	1 = Highest Ph-to-E 2 = Lowest Ph-to-E 3 = Highest Ph-to-Ph 4 = Lowest Ph-to-Ph 5 = Positive Seq	-
Active coordinates	LVRTPTUV	1...10	1
Voltage level 1	LVRTPTUV	0.00...1.20 ms	0.01
Voltage level 2	LVRTPTUV	0.00...1.20 ms	0.01
Voltage level 3	LVRTPTUV	0.00...1.20 ms	0.01
Voltage level 4	LVRTPTUV	0.00...1.20 ms	0.01
Voltage level 5	LVRTPTUV	0.00...1.20 ms	0.01
Voltage level 6	LVRTPTUV	0.00...1.20 ms	0.01
Voltage level 7	LVRTPTUV	0.00...1.20 ms	0.01
Voltage level 8	LVRTPTUV	0.00...1.20 ms	0.01
Voltage level 9	LVRTPTUV	0.00...1.20 ms	0.01
Voltage level 10	LVRTPTUV	0.00...1.20 ms	0.01
Recovery time 1	LVRTPTUV	0...300000 ms	1
Recovery time 2	LVRTPTUV	0...300000 ms	1
Recovery time 3	LVRTPTUV	0...300000 ms	1
Recovery time 4	LVRTPTUV	0...300000 ms	1
Recovery time 5	LVRTPTUV	0...300000 ms	1
Recovery time 6	LVRTPTUV	0...300000 ms	1
Recovery time 7	LVRTPTUV	0...300000 ms	1
Recovery time 8	LVRTPTUV	0...300000 ms	1
Recovery time 9	LVRTPTUV	0...300000 ms	1
Recovery time 10	LVRTPTUV	0...300000 ms	1

Table 96. High-impedance differential protection (HlxPDIF)

Characteristic		Value		
Operation accuracy		Depending on the frequency of the current measured: $f_n \pm 2$ Hz $\pm 1.5\%$ of the set value or $\pm 0.002 \times I_n$		
Start time ¹⁾²⁾	$I_{Fault} = 2.0 \times \text{set Start value}$	Minimum	Typical	Maximum
		12 ms	16 ms	24 ms
		$I_{Fault} = 10 \times \text{set Start value}$	10 ms	12 ms
Reset time		<40 ms		
Reset ratio		Typically 0.96		
Retardation time		<35 ms		
Operate time accuracy in definite time mode		$\pm 1.0\%$ of the set value or ± 20 ms		

1) *Measurement mode* = default (depends on stage), current before fault = $0.0 \times I_n$, $f_n = 50$ Hz, fault current with nominal frequency injected from random phase angle, results based on statistical distribution of 1000 measurements

2) Includes the delay of the signal output contact

Table 97. High-impedance differential protection (HlxPDIF) main settings

Parameter	Function	Value (Range)	Step
Operate value	HlxPDIF	1.0...200.0 % I_n	1
Minimum operate time	HlxPDIF	20...300000 ms	10

Table 98. Circuit breaker uncorresponding position start-up (UPCALH)

Characteristic	Value
Operate time accuracy	$\pm 1.0\%$ of the set value or ± 20 ms

Table 99. Three-independent-phase non-directional overcurrent protection (PH3xPTOC)

Characteristic	Value			
Operation accuracy	PH3LPTOC	Depending on the frequency of the current measured: $f_n \pm 2$ Hz $\pm 1.5\%$ of the set value or $\pm 0.002 \times I_n$		
	PH3HPTOC and PH3IPTOC	$\pm 1.5\%$ of set value or $\pm 0.002 \times I_n$ (at currents in the range of $0.1 \dots 10 \times I_n$) $\pm 5.0\%$ of the set value (at currents in the range of $10 \dots 40 \times I_n$)		
Start time ¹⁾²⁾		Minimum	Typical	Maximum
	PH3IPTOC: $I_{\text{Fault}} = 2 \times \text{set Start value}$	15 ms	16 ms	17 ms
	$I_{\text{Fault}} = 10 \times \text{set Start value}$	11 ms	14 ms	17 ms
	PH3HPTOC and PH3LPTOC: $I_{\text{Fault}} = 2 \times \text{set Start value}$	23 ms	25 ms	28 ms
Reset time	<40 ms			
Reset ratio	Typically 0.96			
Retardation time	<30 ms			
Operate time accuracy in definite time mode	$\pm 1.0\%$ of the set value or ± 20 ms			
Operate time accuracy in inverse time mode	$\pm 5.0\%$ of the theoretical value or ± 20 ms ³⁾			
Suppression of harmonics	RMS: No suppression DFT: -50 dB at $f = n \times f_n$, where $n = 2, 3, 4, 5, \dots$ Peak-to-Peak: No suppression Peak-to-Peak + backup: No suppression			

1) *Measurement mode* = default (depends on stage), current before fault = $0.0 \times I_n$, $f_n = 50$ Hz, fault current in one phase with nominal frequency injected from random phase angle, results based on statistical distribution of 1000 measurements

2) Includes the delay of the signal output contact

3) Maximum *Start value* = $2.5 \times I_n$, *Start value* multiples in range of 1.5...20

Table 100. Three-independent-phase non-directional overcurrent protection (PH3xPTOC) main settings

Parameter	Function	Value (Range)	Step
Start value	PH3LPTOC	$0.05 \dots 5.00 \times I_n$	0.01
	PH3HPTOC	$0.10 \dots 40.00 \times I_n$	0.01
	PH3IPTOC	$1.00 \dots 40.00 \times I_n$	0.01
Time multiplier	PH3LPTOC	0.05...15.00	0.01
	PH3HPTOC	0.05...15.00	0.01
Operate delay time	PH3LPTOC	40...200000 ms	10
	PH3HPTOC	40...200000 ms	10
	PH3IPTOC	20...200000 ms	10
Operating curve type ¹⁾	PH3LPTOC	Definite or inverse time Curve type: 1, 2, 3, 4, 5, 6, 7, 8, 9, 10, 11, 12, 13, 14, 15, 17, 18, 19	
	PH3HPTOC	Definite or inverse time Curve type: 1, 3, 5, 9, 10, 12, 15, 17	
	PH3IPTOC	Definite time	

1) For further reference, see Operation characteristics table

Table 101. Directional three-independent-phase directional overcurrent protection (DPH3xPDOC)

Characteristic	Value	
Operation accuracy	DPH3LPDOC	Depending on the frequency of the current measured: $f_n \pm 2$ Hz Current: $\pm 1.5\%$ of the set value or $\pm 0.002 \times I_n$ Voltage: $\pm 1.5\%$ of the set value or $\pm 0.002 \times U_n$ Phase angle: $\pm 2^\circ$
	DPH3HPDOC	$\pm 1.5\%$ of set value or $\pm 0.002 \times I_n$ (at currents in the range of $0.1 \dots 10 \times I_n$) $\pm 5.0\%$ of the set value (at currents in the range of $10 \dots 40 \times I_n$) Voltage: $\pm 1.5\%$ of the set value or $\pm 0.002 \times U_n$ Phase angle: $\pm 2^\circ$
Start time ¹⁾²⁾		Minimum Typical Maximum
	$I_{\text{Fault}} = 2 \times \text{set Start value}$	38 ms 40 ms 43 ms
Reset time	<40 ms	
Reset ratio	Typically 0.96	
Retardation time	<35 ms	
Operate time accuracy in definite time mode	$\pm 1.0\%$ of the set value or ± 20 ms	
Operate time accuracy in inverse time mode	$\pm 5.0\%$ of the theoretical value or ± 20 ms ³⁾	
Suppression of harmonics	RMS: No suppression DFT: -50 dB at $f = n \times f_n$, where $n = 2, 3, 4, 5, \dots$ Peak-to-Peak: No suppression Peak-to-Peak + backup: No suppression	

1) Measurement mode and Pol quantity = default, current before fault = $0.0 \times I_n$, voltage before fault = $1.0 \times U_n$, $f_n = 50$ Hz, fault current in one phase with nominal frequency injected from random phase angle, results based on statistical distribution of 1000 measurements

2) Includes the delay of the signal output contact

3) Maximum Start value = $2.5 \times I_n$, Start value multiples in range of 1.5...20

Table 102. Directional three-independent-phase directional overcurrent protection (DPH3xPDOC) main settings

Parameter	Function	Value (Range)	Step
Start value	DPH3LPDOC	$0.05 \dots 5.00 \times I_n$	0.01
	DPH3HPDOC	$0.10 \dots 40.00 \times I_n$	0.01
Time multiplier	DPH3xPDOC	0.05...15.00	0.01
Operate delay time	DPH3xPDOC	40...200000 ms	10
Operating curve type ¹⁾	DPH3LPDOC	Definite or inverse time Curve type: 1, 2, 3, 4, 5, 6, 7, 8, 9, 10, 11, 12, 13, 14, 15, 17, 18, 19	
	DPH3HPDOC	Definite or inverse time Curve type: 1, 3, 5, 9, 10, 12, 15, 17	
Directional mode	DPH3xPDOC	1 = Non-directional 2 = Forward 3 = Reverse	
Characteristic angle	DPH3xPDOC	$-179 \dots 180^\circ$	1

1) For further reference, refer to the Operating characteristics table

Table 103. Three-phase overload protection for shunt capacitor banks (COLPTOC)

Characteristic	Value
Operation accuracy	Depending on the frequency of the measured current: $f_n \pm 2$ Hz, and no harmonics 5% of the set value or $0.002 \times I_n$
Start time for overload stage ¹⁾²⁾	Typically 75 ms
Start time for under current stage ²⁾³⁾	Typically 26 ms
Reset time for overload and alarm stage	Typically 60 ms
Reset ratio	Typically 0.96
Operate time accuracy in definite time mode	1% of the set value or ± 20 ms
Operate time accuracy in inverse time mode	10% of the theoretical value or ± 20 ms
Suppression of harmonics for under current stage	DFT: -50 dB at $f = n \times f_n$, where $n = 2,3,4,5,..$

1) Harmonics current before fault = $0.5 \times I_n$, harmonics fault current $1.5 \times \text{Start value}$, results based on statistical distribution of 1000 measurements

2) Includes the delay of the signal output contact

3) Harmonics current before fault = $1.2 \times I_n$, harmonics fault current $0.8 \times \text{Start value}$, results based on statistical distribution of 1000 measurements

Table 104. Three-phase overload protection for shunt capacitor banks (COLPTOC) main settings

Parameter	Function	Value (Range)	Step
Start value overload	COLPTOC	$0.30...1.50 \times I_n$	0.01
Alarm start value	COLPTOC	80...120%	1
Start value Un Cur	COLPTOC	$0.10...0.70 \times I_n$	0.01
Time multiplier	COLPTOC	0.05...2.00	0.01
Alarm delay time	COLPTOC	500...6000000	100
Un Cur delay time	COLPTOC	100...120000	100

Table 105. Current unbalance protection for shunt capacitor banks (CUBPTOC)

Characteristic	Value
Operation accuracy	Depending on the frequency of the measured current: $f_n \pm 2$ Hz 1.5% of the set value or $0.002 \times I_n$
Start time ¹⁾²⁾	Typically 26 ms
Reset time	Typically 40 ms
Reset ratio	Typically 0.96
Operate time accuracy in definite time mode	1% of the theoretical value or ± 20 ms
Operate time accuracy in inverse definite minimum time mode	5% of the theoretical value or ± 20 ms
Suppression of harmonics	DFT: -50 dB at $f = n \times f_n$, where $n = 2,3,4,5,..$

1) Fundamental frequency current = $1.0 \times I_n$, current before fault = $0.0 \times I_n$, fault current = $2.0 \times \text{Start value}$, results based on statistical distribution of 1000 measurements

2) Includes the delay of the signal output contact

Table 106. Current unbalance protection for shunt capacitor banks (CUBPTOC) main settings

Parameter	Function	Value (Range)	Step
Alarm mode	CUBPTOC	1 = Normal 2 = Element counter	-
Start value	CUBPTOC	$0.01...1.00 \times I_n$	0.01
Alarm start value	CUBPTOC	$0.01...1.00 \times I_n$	0.01
Time multiplier	CUBPTOC	0.05...15.00	0.01
Operating curve type ¹⁾	CUBPTOC	Definite or inverse time Curve type: 1, 2, 3, 4, 5, 6, 7, 8, 9, 10, 11, 12, 13, 14, 15, 17, 18, 19	
Operate delay time	CUBPTOC	50...200000 ms	10
Alarm delay time	CUBPTOC	50...200000 ms	10

1) For further reference, refer to the Operating characteristics table

Table 107. Shunt capacitor bank switching resonance protection, current based (SRCPTOC)

Characteristic	Value
Operation accuracy	Depending on the frequency of the measured current: $f_n \pm 2$ Hz Operate value accuracy: $\pm 3\%$ of the set value or $\pm 0.002 \times I_n$ (for 2 nd order Harmonics) $\pm 1.5\%$ of the set value or $\pm 0.002 \times I_n$ (for 3 rd order < Harmonics < 10th order) $\pm 6\%$ of the set value or $\pm 0.004 \times I_n$ (for Harmonics ≥ 10 th order)
Reset time	Typically 45 ms or maximum 50 ms
Retardation time	Typically 0.96
Retardation time	<35 ms
Operate time accuracy in definite time mode	$\pm 1.0\%$ of the set value or ± 20 ms
Suppression of harmonics	-50 dB at $f = f_n$

Table 108. Shunt capacitor bank switching resonance protection, current based (SRCPTOC) main settings

Parameter	Function	Value (Range)	Step
Alarm start value	SRCPTOC	$0.03...0.50 \times I_n$	0.01
Start value	SRCPTOC	$0.03...0.50 \times I_n$	0.01
Tuning harmonic Num	SRCPTOC	1...11	1
Operate delay time	SRCPTOC	120...360000 ms	1
Alarm delay time	SRCPTOC	120...360000 ms	1

Table 109. Operation characteristics

Parameter	Value (Range)
Operating curve type	1 = ANSI Ext. inv. 2 = ANSI Very. inv. 3 = ANSI Norm. inv. 4 = ANSI Mod inv. 5 = ANSI Def. Time 6 = L.T.E. inv. 7 = L.T.V. inv. 8 = L.T. inv. 9 = IEC Norm. inv. 10 = IEC Very inv. 11 = IEC inv. 12 = IEC Ext. inv. 13 = IEC S.T. inv. 14 = IEC L.T. inv 15 = IEC Def. Time 17 = Programmable 18 = RI type 19 = RD type
Operating curve type (voltage protection)	5 = ANSI Def. Time 15 = IEC Def. Time 17 = Inv. Curve A 18 = Inv. Curve B 19 = Inv. Curve C 20 = Programmable 21 = Inv. Curve A 22 = Inv. Curve B 23 = Programmable

Control functions

Table 110. Autoreclosing (DARREC)

Characteristic	Value
Operate time accuracy	$\pm 1.0\%$ of the set value or ± 20 ms

Table 111. Synchronism and energizing check (SECRSYN)

Characteristic	Value
Operation accuracy	Depending on the frequency of the voltage measured: $f_n \pm 1$ Hz Voltage: $\pm 3.0\%$ of the set value or $\pm 0.01 \times U_n$ Frequency: ± 10 mHz Phase angle: $\pm 3^\circ$
Reset time	<50 ms
Reset ratio	Typically 0.96
Operate time accuracy in definite time mode	$\pm 1.0\%$ of the set value or ± 20 ms

Table 112. Synchronism and energizing check (SECRSYN) main settings

Parameter	Function	Value (Range)	Step
Live dead mode	SECRSYN	-1 = Off 1 = Both Dead 2 = Live L, Dead B 3 = Dead L, Live B 4 = Dead Bus, L Any 5 = Dead L, Bus Any 6 = One Live, Dead 7 = Not Both Live	-
Difference voltage	SECRSYN	$0.01 \dots 0.50 \times U_n$	0.01
Difference frequency	SECRSYN	$0.001 \dots 0.100 \times f_n$	0.001
Difference angle	SECRSYN	$5 \dots 90^\circ$	1
Synchrocheck mode	SECRSYN	1 = Off 2 = Synchronous 3 = Asynchronous	-
Dead line value	SECRSYN	$0.1 \dots 0.8 \times U_n$	0.1
Live line value	SECRSYN	$0.2 \dots 1.0 \times U_n$	0.1
Close pulse	SECRSYN	200...60000 ms	10
Max energizing V	SECRSYN	$0.50 \dots 1.15 \times U_n$	0.01
Control mode	SECRSYN	1 = Continuous 2 = Command	-
Phase shift	SECRSYN	$-180 \dots 180^\circ$	1
Minimum Syn time	SECRSYN	0...60000 ms	10
Maximum Syn time	SECRSYN	100...6000000 ms	10
Energizing time	SECRSYN	100...60000 ms	10
Closing time of CB	SECRSYN	40...250 ms	10

Condition monitoring and supervision functions

Table 113. Circuit-breaker condition monitoring (SSCBR)

Characteristic	Value
Current measuring accuracy	$\pm 1.5\%$ or $\pm 0.002 \times I_n$ (at currents in the range of $0.1 \dots 10 \times I_n$) $\pm 5.0\%$ (at currents in the range of $10 \dots 40 \times I_n$)
Operate time accuracy	$\pm 1.0\%$ of the set value or ± 20 ms
Travelling time measurement	+10 ms / -0 ms

Table 114. Current circuit supervision (CCSPVC)

Characteristic	Value
Operate time ¹⁾	<30 ms

1) Including the delay of the output contact

Table 115. Current circuit supervision (CCSPVC) main settings

Parameter	Function	Value (Range)	Step
Start value	CCSPVC	$0.05 \dots 0.20 \times I_n$	0.01
Max operate current	CCSPVC	$1.00 \dots 5.00 \times I_n$	0.01

Table 116. Current transformer supervision for high-impedance protection scheme (HZCCxSPVC)

Characteristic	Value
Operation accuracy	Depending on the frequency of the current measured: $f_n \pm 2$ Hz $\pm 1.5\%$ of the set value or $\pm 0.002 \times I_n$
Reset time	<40 ms
Reset ratio	Typically 0.96
Retardation time	<35 ms
Operate time accuracy in definite time mode	$\pm 1.0\%$ of the set value or ± 20 ms

Table 117. Fuse failure supervision (SEQSPVC)

Characteristic	Value		
Operate time ¹⁾	NPS function	$U_{Fault} = 1.1 \times \text{set } Neg \text{ Seq voltage } Lev$	<33 ms
		$U_{Fault} = 5.0 \times \text{set } Neg \text{ Seq voltage } Lev$	<18 ms
	Delta function	$\Delta U = 1.1 \times \text{set } Voltage \text{ change rate}$	<30 ms
		$\Delta U = 2.0 \times \text{set } Voltage \text{ change rate}$	<24 ms

1) Includes the delay of the signal output contact, $f_n = 50$ Hz, fault voltage with nominal frequency injected from random phase angle, results based on statistical distribution of 1000 measurements

Table 118. Runtime counter for machines and devices (MDSOPT)

Description	Value
Motor runtime measurement accuracy ¹⁾	±0.5%

1) Of the reading, for a stand-alone relay, without time synchronization

Measurement functions

Table 119. Three-phase current measurement (CMMXU)

Characteristic	Value
Operation accuracy	Depending on the frequency of the measured current: $f_n \pm 2$ Hz $\pm 0.5\%$ or $\pm 0.002 \times I_n$ (at currents in the range of $0.01 \dots 4.00 \times I_n$)
Suppression of harmonics	DFT: -50 dB at $f = n \times f_n$, where $n = 2, 3, 4, 5, \dots$ RMS: No suppression

Table 120. Sequence current measurement (CSMSQI)

Characteristic	Value
Operation accuracy	Depending on the frequency of the measured current: $f/f_n = \pm 2$ Hz $\pm 1.0\%$ or $\pm 0.002 \times I_n$ at currents in the range of $0.01 \dots 4.00 \times I_n$
Suppression of harmonics	DFT: -50 dB at $f = n \times f_n$, where $n = 2, 3, 4, 5, \dots$

Table 121. Residual current measurement (RESCMMXU)

Characteristic	Value
Operation accuracy	Depending on the frequency of the current measured: $f/f_n = \pm 2$ Hz $\pm 0.5\%$ or $\pm 0.002 \times I_n$ at currents in the range of $0.01 \dots 4.00 \times I_n$
Suppression of harmonics	DFT: -50 dB at $f = n \times f_n$, where $n = 2, 3, 4, 5, \dots$ RMS: No suppression

Table 122. Three-phase voltage measurement (VMMXU)

Characteristic	Value
Operation accuracy	Depending on the frequency of the voltage measured: $f_n \pm 2$ Hz At voltages in range $0.01 \dots 1.15 \times U_n$ $\pm 0.5\%$ or $\pm 0.002 \times U_n$
Suppression of harmonics	DFT: -50 dB at $f = n \times f_n$, where $n = 2, 3, 4, 5, \dots$ RMS: No suppression

Table 123. Single-phase voltage measurement (VAMMXU)

Characteristic	Value
Operation accuracy	Depending on the frequency of the voltage measured: $f_n \pm 2$ Hz At voltages in range $0.01 \dots 1.15 \times U_n$ $\pm 0.5\%$ or $\pm 0.002 \times U_n$
Suppression of harmonics	DFT: -50 dB at $f = n \times f_n$, where $n = 2, 3, 4, 5, \dots$ RMS: No suppression

Table 124. Residual voltage measurement (RESVMMXU)

Characteristic	Value
Operation accuracy	Depending on the frequency of the measured current: $f/f_n = \pm 2$ Hz $\pm 0.5\%$ or $\pm 0.002 \times U_n$
Suppression of harmonics	DFT: -50 dB at $f = n \times f_n$, where $n = 2, 3, 4, 5, \dots$ RMS: No suppression

Table 125. Sequence voltage measurement (VSMSQI)

Characteristic	Value
Operation accuracy	Depending on the frequency of the voltage measured: $f_n \pm 2$ Hz At voltages in range $0.01 \dots 1.15 \times U_n$ $\pm 1.0\%$ or $\pm 0.002 \times U_n$
Suppression of harmonics	DFT: -50 dB at $f = n \times f_n$, where $n = 2, 3, 4, 5, \dots$

Table 126. Three-phase power and energy measurement (PEMMXU)

Characteristic	Value
Operation accuracy	At all three currents in range $0.10 \dots 1.20 \times I_n$ At all three voltages in range $0.50 \dots 1.15 \times U_n$ At the frequency $f_n \pm 1$ Hz $\pm 1.5\%$ for apparent power S $\pm 1.5\%$ for active power P and active energy ¹⁾ $\pm 1.5\%$ for reactive power Q and reactive energy ²⁾ ± 0.015 for power factor
Suppression of harmonics	DFT: -50 dB at $f = n \times f_n$, where $n = 2, 3, 4, 5, \dots$

1) $|PF| > 0.5$ which equals $|\cos\phi| > 0.5$ 2) $|PF| < 0.86$ which equals $|\sin\phi| > 0.5$

Table 127. Frequency measurement (FMMXU)

Characteristic	Value
Operation accuracy	± 10 mHz (in measurement range 35...75 Hz)

Fault location functions

Table 128. Fault locator (SCEFRFLO)

Characteristic	Value
Measurement accuracy	At the frequency $f = f_n$ Impedance: $\pm 2.5\%$ or $\pm 0.25 \Omega$ Distance: $\pm 2.5\%$ or $\pm 0.16 \text{ km}/0.1 \text{ mile}$ XC0F_CALC: $\pm 2.5\%$ or $\pm 50 \Omega$ IFLT_PER_ILD: $\pm 5\%$ or ± 0.05

Table 129. Fault locator (SCEFRFLO) main settings

Parameter	Function	Value (Range)	Step
Z Max phase load	SCEFRFLO	1.0...10000.00 Ω	0.1
Ph leakage Ris	SCEFRFLO	20...1000000 Ω	1
Ph capacitive React	SCEFRFLO	10...1000000 Ω	1
R1 line section A	SCEFRFLO	0.000...1000.000 Ω/pu	0.001
X1 line section A	SCEFRFLO	0.000...1000.000 Ω/pu	0.001
R0 line section A	SCEFRFLO	0.000...1000.000 Ω/pu	0.001
X0 line section A	SCEFRFLO	0.000...1000.000 Ω/pu	0.001
Line Len section A	SCEFRFLO	0.000...1000.000 pu	0.001

Power quality functions

Table 130. Voltage variation (PHQVVR)

Characteristic	Value
Operation accuracy	±1.5% of the set value or ±0.2% of reference voltage
Reset ratio	Typically 0.96 (Swell), 1.04 (Dip, Interruption)

Table 131. Voltage variation (PHQVVR) main settings

Parameter	Function	Value (Range)	Step
Voltage dip set 1	PHQVVR	10.0...100.0%	0.1
Voltage dip set 2	PHQVVR	10.0...100.0%	0.1
Voltage dip set 3	PHQVVR	10.0...100.0%	0.1
Voltage swell set 1	PHQVVR	100.0...140.0%	0.1
Voltage swell set 2	PHQVVR	100.0...140.0%	0.1
Voltage swell set 3	PHQVVR	100.0...140.0%	0.1
Voltage Int set	PHQVVR	0.0...100.0%	0.1
VVa Dur Max	PHQVVR	100...3600000 ms	100

Table 132. Voltage unbalance (VSQVUB)

Characteristic	Value
Operation accuracy	±1.5% of the set value or $\pm 0.002 \times U_n$
Reset ratio	Typically 0.96

Table 133. Voltage unbalance (VSQVUB) main settings

Parameter	Function	Value (Range)	Step
Operation	VSQVUB	1 = on 5 = off	-
Unb detection method	VSQVUB	1 = Neg Seq 2 = Zero Seq 3 = Neg to Pos Seq 4 = Zero to Pos Seq 5 = Ph vectors Comp	-

Other functions

Table 134. Pulse timer (PTGAPC)

Characteristic	Value
Operate time accuracy	$\pm 1.0\%$ of the set value or ± 20 ms

Table 135. Time delay off (8 pcs) (TOFPAGC)

Characteristic	Value
Operate time accuracy	$\pm 1.0\%$ of the set value or ± 20 ms

Table 136. Time delay on (8 pcs) (TONGAPC)

Characteristic	Value
Operate time accuracy	$\pm 1.0\%$ of the set value or ± 20 ms

22. Local HMI

The relay supports process information and status monitoring from the relay's local HMI via its display and indication/alarm LEDs. The local LHMI also enables control operations for the equipment connected and controlled by the relay, either via display or via manual push buttons available on the local HMI.

LCD display offers front-panel user interface functionality with menu navigation and menu views. In addition, the display includes a user-configurable two-page single-line diagram (SLD) with a position indication for the associated primary equipment and primary measurements from the process. The SLD can be modified according to user requirements by using Graphical Display Editor in PCM600.

The local HMI also includes 11 programmable LEDs. These LEDs can be configured to show alarms and indications as needed by PCM600 graphical configuration tool. The LEDs include two separately controllable colors, red and green, making one LED able to indicate better the different states of the monitored object.

The relay also includes 16 configurable manual push buttons, which can freely be configured by the PCM600 graphical configuration tool. These buttons can be configured to control the relay's internal features for example changing setting group, trigger disturbance recordings and changing operation modes for functions or to control relay's external equipment, for example opening or closing the equipment, via relay's binary outputs. These buttons also include a small indication LED for each button. This LED is freely configurable, making it possible to use push button LEDs to indicate button activities or as additional indication/alarm LEDs in addition to the 11 programmable LEDs.

The local HMI includes a push button (L/R) for the local/remote operation of the relay. When the relay is in the local mode, the relay can be operated only by using the local front-panel user interface. When the relay is in the remote mode, the relay can execute commands sent remotely. The relay supports the remote selection of local/remote mode via a binary input. This feature facilitates, for example, the use of an external switch at the substation to ensure that all the relays are in the local mode during maintenance work and that the circuit breakers cannot be operated remotely from the network control center.

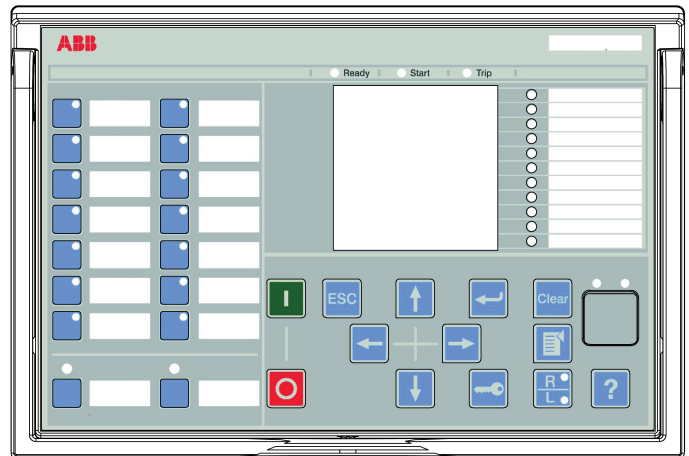

Figure 18. Example of the LHMI

23. Mounting methods

By means of appropriate mounting accessories the standard relay case can be flush mounted, semi-flush mounted or wall mounted.

Further, the relays can be mounted in any standard 19" instrument cabinet by means of 19" mounting panels available with cut-outs for one relay. Alternatively, the relay can be mounted in 19" instrument cabinets by means of 4U Combiflex equipment frames.

For the routine testing purposes, the relay cases can be equipped with test switches, type RTXP 24, which can be mounted side by side with the relay cases.

Mounting methods

- Flush mounting
- Semi-flush mounting
- Rack mounting
- Wall mounting
- Mounting to a 19" equipment frame
- Mounting with a RTXP 24 test switch to a 19" rack

Panel cut-out for flush mounting

- Height: 162 ±1 mm
- Width: 248 ±1 mm

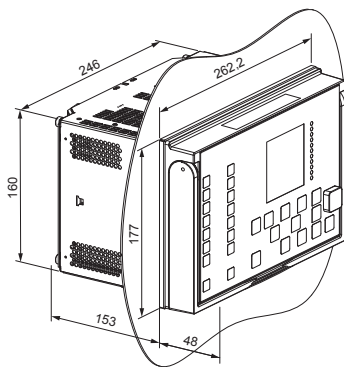

Figure 19. Flush mounting

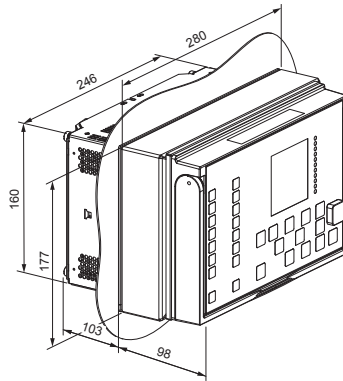

Figure 20. Semi-flush mounting

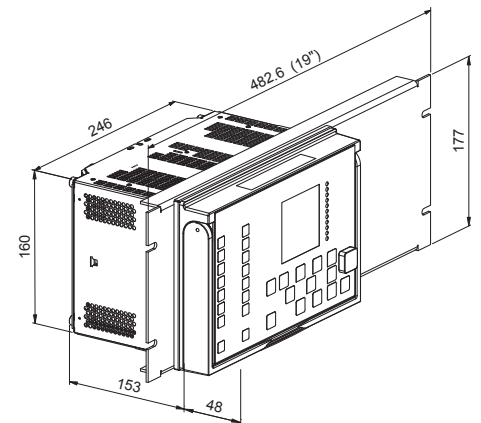

Figure 21. Rack mounting

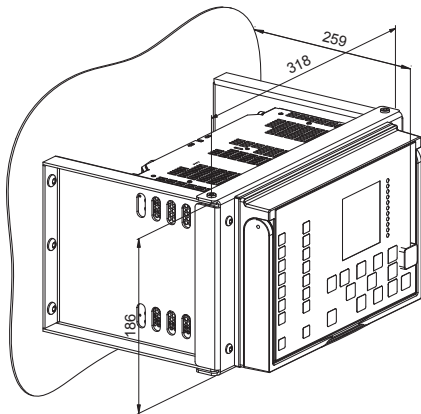

Figure 22. Wall mounting

24. Relay case and plug-in unit

For safety reasons, the relay cases for current measuring relays are provided with automatically operating contacts for short-circuiting the CT secondary circuits when a relay unit is withdrawn from its case. The relay case is further provided with a mechanical coding system preventing current measuring relay units from being inserted into a relay case for a voltage measuring relay unit and vice versa, that is, the relay cases are assigned to a certain type of plug-in unit.

25. Selection and ordering data

The relay type and serial number label identifies the protection and control relay. The label is placed above the HMI on the upper part of the plug-in-unit. An order code label is placed on the side of the plug-in unit as well as inside the case. The order code consists of a string of letters and digits generated from the relay's hardware and software modules.

[Product Selection Tool](#) (PST), a Next-Generation Order Number Tool, supports order code creation for ABB Distribution Automation IEC products with emphasis on but not exclusively for the Relion product family. PST is an easy to use, online tool always containing the latest product information. The complete order code can be created with detailed specification and the result can be printed and mailed. Registration is required.

Use [ABB Library](#) to access the selection and ordering information and to generate the order number.

#	Description	
1	IED	
	620 series IED (including case)	<input type="text" value="N"/>
	Complete Relay with conformal coating	5
2	Standard	
	IEC	<input type="text" value="B"/>
	CN	C
3	Main application	
	Feeder protection and control	<input type="text" value="F"/>
4	Functional application	
	Example configuration	<input type="text" value="N"/>
5-6	Analog inputs and outputs	
	4I (I ₀ 1/5 A) + 5U + 24BI + 14BO	<input type="text" value="AA"/>
	4I (I ₀ 0,2/1 A) + 5U + 24BI + 14BO	AB
	Sensors (3I + 3U) + 1CT + 16BI + 14BO	AC
7-8	Optional board	
	Optional I/Os 8BI+ 4BO	AA
	Optional RTDs 6RTD in + 2mA in	AB
	Optional Fast I/Os 8BI + 3HSO	AC
	No optional board	<input type="text" value="NN"/>

N B F N A A N N A B C 1 B N N 1 1 G

NBFNAANN**ABC**1BNN11G

9 - 10	Communication (Serial/Ethernet)	
	Serial RS 485, incl. an input for IRIG-B + Ethernet 100Base FX (1xLC)	AA
	Serial RS 485, incl. an input for IRIG-B + Ethernet 100Base TX (1xRJ45)	AB
	Serial RS 485, incl. an input for IRIG-B	AN
	Serial glass fibre (ST) + Ethernet 100Base TX (1xRJ45) + Serial RS 485 connector, RS 232/485 D-Sub 9 connector + input for IRIG-B (cannot be combined with arc protection)	BB
	Serial glass fibre (ST) + Ethernet 100Base TX and FX (1xLC, 2xRJ45) with HSR/PRP	BC
	Serial glass fibre (ST) + Ethernet 100Base TX (3xRJ45) with HSR/PRP	BD
	Serial glass fibre (ST) + Ethernet 100Base TX and FX (2xLC, 1xRJ45) with HSR/PRP	BE
	Serial glass fibre (ST) + Ethernet 100Base TX and FX (1xLC, 2xRJ45) with HSR/PRP and IEC61850-9-2LE	BF
	Serial glass fibre (ST) + Ethernet 100Base TX (3xRJ45) with HSR/PRP and IEC61850-9-2LE	BG
	Serial glass fibre (ST) + Ethernet 100Base TX and FX (2xLC, 1xRJ45) with HSR/PRP and IEC61850-9-2LE	BH
	Serial glass fibre (ST) + Serial RS 485 connector, RS 232/485 D-Sub 9 connector + input for IRIG-B (cannot be combined with arc protection)	BN
	RS 232/485 (including IRIG-B) + Ethernet 100Base TX (1xRJ45) (cannot be combined with arc protection)	CB
	RS 232/485 + RS 485/ Glassfiber ST (including IRIG-B) (cannot be combined with arc protection)	CN
	Ethernet 100Base FX (1xLC)	NA
	Ethernet 100Base TX (1xRJ45)	NB
	Ethernet 100Base TX and FX (1xLC, 2xRJ45) with HSR/PRP	NC
	Ethernet 100Base TX (3xRJ45) with HSR/PRP	ND
	Ethernet 100Base TX and FX (2xLC, 1xRJ45) with HSR/PRP	NE
	Ethernet 100Base TX and FX (1xLC, 2xRJ45) with HSR/PRP and IEC61850-9-2LE	NF
	Ethernet 100Base TX (3xRJ45) with HSR/PRP and IEC61850-9-2LE	NG
	Ethernet 100Base TX and FX (2xLC, 1xRJ45) with HSR/PRP and IEC61850-9-2LE	NH
	No communication module	NN

If serial communication is chosen, please choose a serial communication module including Ethernet (for example "BC") if a service bus for PCM600 or the WebHMI is required.

N B F N A A N N A B C 1 B N N 1 1 G

#	Description	
11	Communication protocols	
	IEC 61850 (for Ethernet communication modules and IEDs without a communication module)	A
	Modbus (for Ethernet/serial or Ethernet + serial communication modules)	B
	IEC 61850 + Modbus (for Ethernet or serial + Ethernet communication modules)	<input type="checkbox"/> C
	IEC 60870-5-103 (for serial or Ethernet + serial communication modules)	D
	DNP3 (for Ethernet/serial or Ethernet + serial communication modules)	E
	IEC 61850 + IEC 60870-5-103 (for serial + Ethernet communication modules)	G
	IEC 61850 + DNP3 (for Ethernet or serial + Ethernet communication modules)	H
12	Language	
	English	<input type="checkbox"/> 1
	English and Chinese	2
13	Front panel	
	Large LCD with Single Line Diagram - IEC	<input type="checkbox"/> B
	Large LCD with Single Line Diagram - CN	D
14	Option 1	
	Arc protection (requires a communication module, cannot be combined with com. module options BN, BB, CB and CN)	B
	None	<input type="checkbox"/> N
15	Option 2	
	Fault locator	F
	Capacitor bank protection package	C
	Intertie/Interconnection/Distributed generation protection package	D
	Power protection package	P
	All options: Fault locator + Capacitor bank protection + Intertie/Interconnection/Distributed generation protection + Power protection	L
	None	<input type="checkbox"/> N
16	Power supply	
	Power supply 48-250 VDC, 100-240 VAC	<input type="checkbox"/> 1
	Power supply 24-60 VDC	2
17	Reserved	
18	Product version 2.0 FP1	<input type="checkbox"/> 1G

Example code: **NBFNAANNABC1BNN11G**

Your ordering code:

Digit (#)	1	2	3	4	5	6	7	8	9	10	11	12	13	14	15	16	17	18
Code	<input type="text"/>	<input type="text"/>	<input type="text"/>	<input type="text"/>	<input type="text"/>	<input type="text"/>	<input type="text"/>	<input type="text"/>	<input type="text"/>	<input type="text"/>	<input type="text"/>	<input type="text"/>	<input type="text"/>	<input type="text"/>	<input type="text"/>	<input type="text"/>	<input type="text"/>	<input type="text"/>

Figure 23. Ordering key for complete protection relays

Feeder Protection and Control	1MRS757844 E
REF620	
Product version: 2.0 FP1	

26. Accessories and ordering data

Table 137. Cables

Item	Order number
Cable for optical sensors for arc protection 1.5 m	1MRS120534-1.5
Cable for optical sensors for arc protection 3.0 m	1MRS120534-3.0
Cable for optical sensors for arc protection 5.0 m	1MRS120534-5.0

Table 138. Mounting accessories

Item	Order number
Semi-flush mounting kit	2RCA030573A0001
Wall mounting kit	2RCA030894A0001
19" rack mounting kit with cut-out for one relay	2RCA031135A0001
19" rack mounting kit for one relay and one RTXP24 test switch (the test switch and wire harness are not included in the delivery)	2RCA032818A0001
Mounting bracket for one relay with test switch RTXP in 4U Combiflex (RHGT 19" variant C) (the test switch, wire harness and Combiflex RGHT 19" variant C are not included in the delivery)	2RCA032826A0001
Functional earthing flange for RTD modules	2RCA036978A0001 ¹⁾

1) Cannot be used when the IED is mounted with the Combiflex 19" equipment frame (2RCA032826A0001).

27. Tools

The protection relay is delivered as a pre-configured unit including the example configuration. The default parameter setting values can be changed from the front-panel user interface, the Web browser-based user interface (Web HMI) or the PCM600 tool in combination with the relay-specific connectivity package.

The Protection and Control IED Manager PCM600 offers extensive relay configuration functions such as relay signal configuration, application configuration, graphical display configuration including single line diagram configuration, and IEC 61850 communication configuration including horizontal GOOSE communication.

When the Web browser-based user interface is used, the protection relay can be accessed either locally or remotely

using a Web browser (Internet Explorer). For security reasons, the Web browser-based user interface is disabled by default but it can be enabled via the front-panel user interface. The Web HMI functionality can be limited to read-only access.

The relay connectivity package is a collection of software and specific relay information, which enables system products and tools to connect and interact with the protection relay. The connectivity packages reduce the risk of errors in system integration, minimizing device configuration and setup times. Further, the connectivity packages for protection relays of this product series include a flexible update tool for adding one additional local HMI language to the protection relay. The update tool is activated using PCM600, and it enables multiple updates of the additional HMI language, thus offering flexible means for possible future language updates.

Table 139. Tools

Configuration and setting tools	Version
PCM600	2.6 (Rollup 20150626) or later
Web browser-based user interface	IE 8.0, IE 9.0, IE 10.0 or IE 11.0
REF620 Connectivity Package	2.1 or later

Table 140. Supported functions

Function	Web HMI	PCM600
Relay parameter setting	•	•
Saving of relay parameter settings in the relay	•	•
Signal monitoring	•	•
Disturbance recorder handling	•	•
Alarm LED viewing	•	•
Access control management	•	•
Relay signal configuration (Signal Matrix)	-	•
Modbus® communication configuration (communication management)	-	•
DNP3 communication configuration (communication management)	-	•
IEC 60870-5-103 communication configuration (communication management)	-	•
Saving of relay parameter settings in the tool	-	•
Disturbance record analysis	-	•
XRIO parameter export/import	-	•
Graphical display configuration	-	•
Application configuration	-	•
IEC 61850 communication configuration, GOOSE (communication configuration)	-	•
Phasor diagram viewing	•	-
Event viewing	•	•
Saving of event data on the user's PC	•	•
Online monitoring	-	•

• = Supported

28. Cyber security

The relay supports role based user authentication and authorization. It can store 2048 audit trail events to a non-volatile memory. The non-volatile memory is based on a memory type which does not need battery backup or regular component exchange to maintain the memory storage. FTP

and Web HMI use TLS encryption with a minimum of 128 bit key length protecting the data in transit. In this case the used communication protocols are FTPS and HTTPS. All rear communication ports and optional protocol services can be deactivated according to the required system setup.

29. Connection diagrams

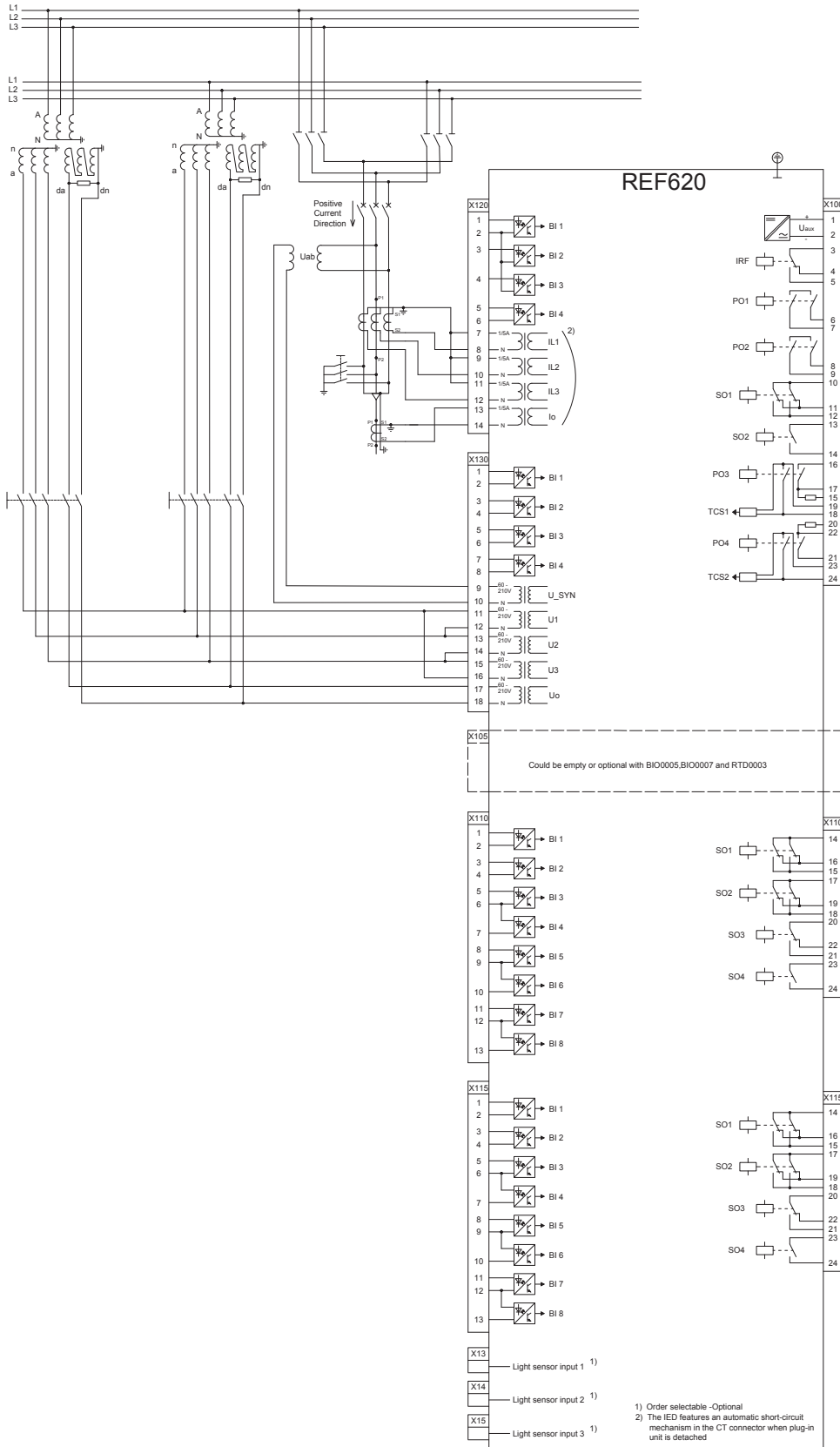

Figure 24. Connection diagram for the configuration with CTs and VTs

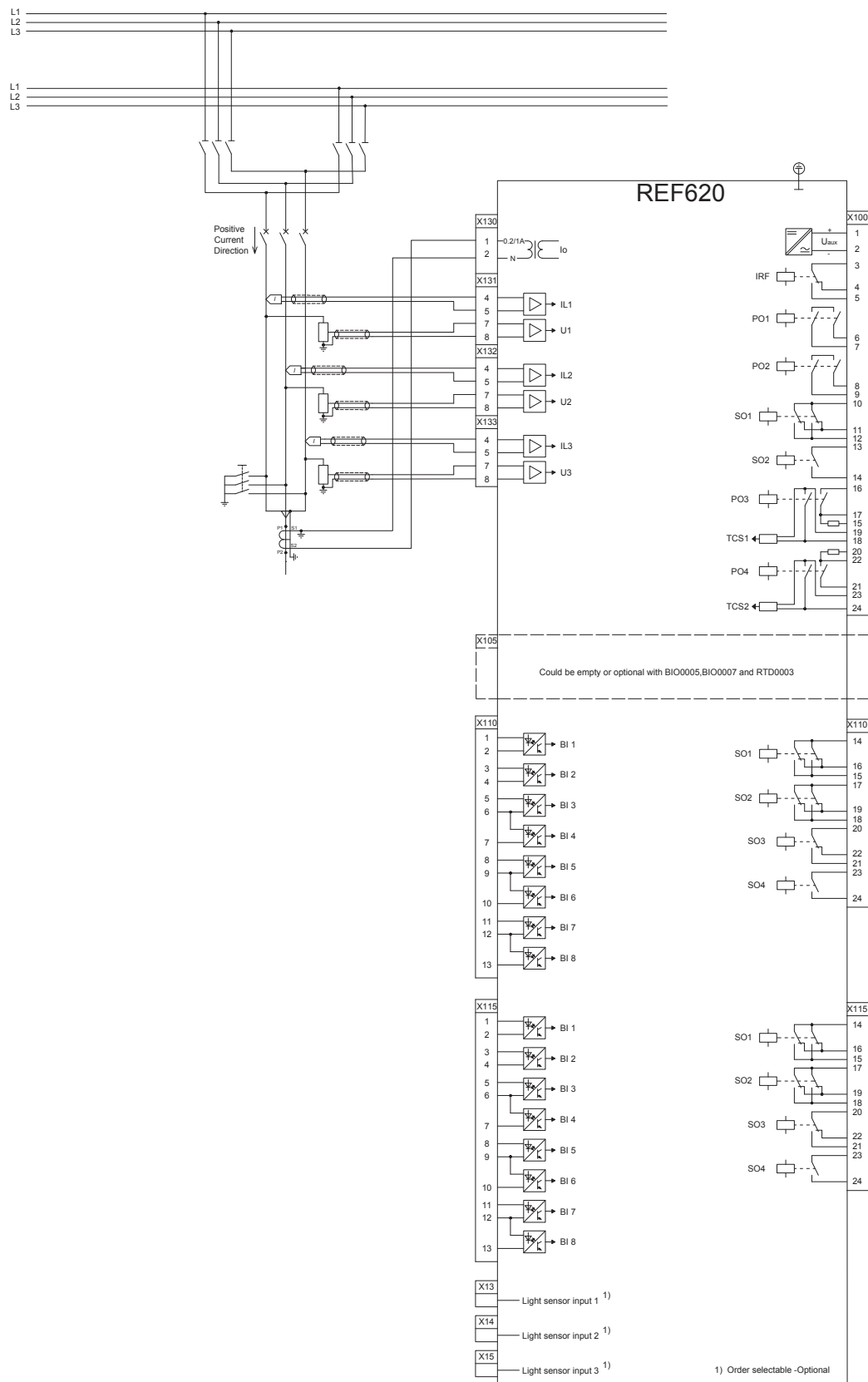

Figure 25. Connection diagram for the configuration with sensors

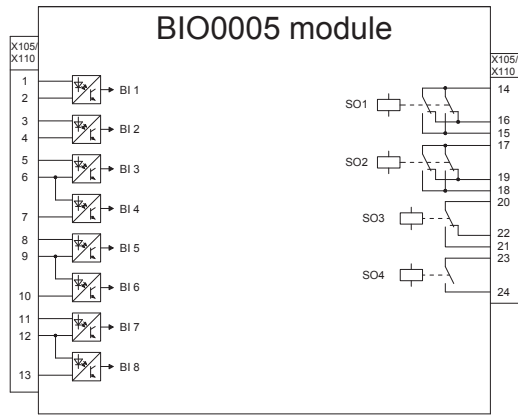

Figure 26. Optional BIO0005 module (slot X105)

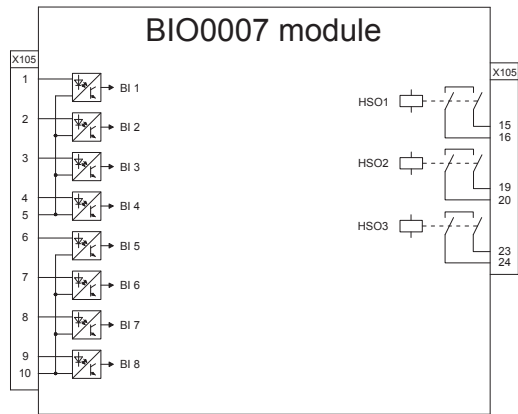

Figure 27. Optional BIO0007 module for fast outputs (slot X105)

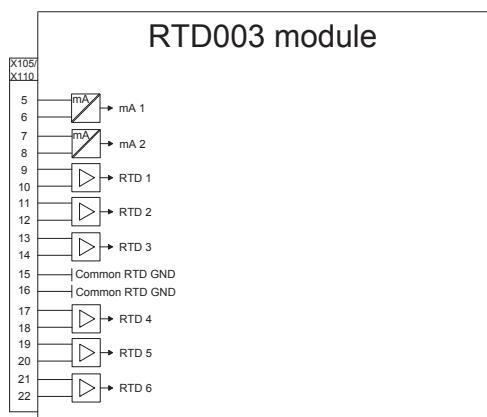

Figure 28. Optional RTD0003 module (slot X105)

30. Certificates

DNV GL has issued an IEC 61850 Edition 2 Certificate Level A1 for Relion® 620 series. Certificate number: 74108008-OPE/INC 15-2319.

DNV GL has issued an IEC 61850 Edition 1 Certificate Level A1 for Relion® 620 series. Certificate number: 74108008-OPE/INC 15-2323.

Additional certificates can be found on the [product page](#).

31. References

The www.abb.com/substationautomation portal provides information on the entire range of distribution automation products and services.

The latest relevant information on the REF620 protection and control relay is found on the [product page](#). Scroll down the page to find and download the related documentation.

32. Functions, codes and symbols

Table 141. Functions included in the relay

Function	IEC 61850	IEC 60617	ANSI
Protection			
Three-phase non-directional overcurrent protection, low stage	PHLPTOC1	3I> (1)	51P-1 (1)
Three-phase non-directional overcurrent protection, high stage	PHHPTOC1	3I>> (1)	51P-2 (1)
	PHHPTOC2	3I>> (2)	51P-2 (2)
Three-phase non-directional overcurrent protection, instantaneous stage	PHIPTOC1	3I>>> (1)	50P/51P (1)
Three-phase directional overcurrent protection, low stage	DPHLPDOC1	3I> -> (1)	67-1 (1)
	DPHLPDOC2	3I> -> (2)	67-1 (2)
Three-phase directional overcurrent protection, high stage	DPHHPDOC1	3I>> -> (1)	67-2 (1)
	DPHHPDOC2	3I>> -> (2)	67-2 (2)
Three-phase voltage-dependent overcurrent protection	PHPVOC1	3I(U)> (1)	51V (1)
	PHPVOC2	3I(U)> (2)	51V (2)
Non-directional earth-fault protection, low stage	EFLPTOC1	Io> (1)	51N-1 (1)
	EFLPTOC2	Io> (2)	51N-1 (2)
Non-directional earth-fault protection, high stage	EFHPTOC1	Io>> (1)	51N-2 (1)
Non-directional earth-fault protection, instantaneous stage	EFIPTOC1	Io>>> (1)	50N/51N (1)
Directional earth-fault protection, low stage	DEFLPDEF1	Io> -> (1)	67N-1 (1)
	DEFLPDEF2	Io> -> (2)	67N-1 (2)
	DEFLPDEF3	Io> -> (3)	67N-1 (3)
Directional earth-fault protection, high stage	DEFHPDEF1	Io>> -> (1)	67N-2 (1)
Admittance-based earth-fault protection	EFPADM1	Yo> -> (1)	21YN (1)
	EFPADM2	Yo> -> (2)	21YN (2)
	EFPADM3	Yo> -> (3)	21YN (3)
Wattmetric-based earth-fault protection	WPWDE1	Po> -> (1)	32N (1)
	WPWDE2	Po> -> (2)	32N (2)
	WPWDE3	Po> -> (3)	32N (3)
Multifrequency admittance-based earth-fault protection	MFADPSDE1	Io> -> Y (1)	67YN (1)
Transient/intermittent earth-fault protection	INTRPTEF1	Io> -> IEF (1)	67NIEF (1)
Harmonics-based earth-fault protection	HAEFPTOC1	Io>HA (1)	51NHA (1)
Negative-sequence overcurrent protection	NSPTOC1	I2> (1)	46 (1)
	NSPTOC2	I2> (2)	46 (2)
Phase discontinuity protection	PDNSPTOC1	I2/I1> (1)	46PD (1)
Residual overvoltage protection	ROVPTOV1	Uo> (1)	59G (1)
	ROVPTOV2	Uo> (2)	59G (2)
	ROVPTOV3	Uo> (3)	59G (3)

Table 141. Functions included in the relay, continued

Function	IEC 61850	IEC 60617	ANSI
Three-phase undervoltage protection	PHPTUV1	3U< (1)	27 (1)
	PHPTUV2	3U< (2)	27 (2)
	PHPTUV3	3U< (3)	27 (3)
	PHPTUV4	3U< (4)	27 (4)
Single-phase undervoltage protection, secondary side	PHAPTUV1	U_A< (1)	27_A (1)
Three-phase overvoltage protection	PHPTOV1	3U> (1)	59 (1)
	PHPTOV2	3U> (2)	59 (2)
	PHPTOV3	3U> (3)	59 (3)
Single-phase overvoltage protection, secondary side	PHAPTUV1	U_A> (1)	59_A (1)
Positive-sequence undervoltage protection	PSPTUV1	U1< (1)	47U+ (1)
	PSPTUV2	U1< (2)	47U+ (2)
Negative-sequence overvoltage protection	NSPTOV1	U2> (1)	47O- (1)
	NSPTOV2	U2> (2)	47O- (2)
Frequency protection	FRPFRQ1	f>/f<,df/dt (1)	81 (1)
	FRPFRQ2	f>/f<,df/dt (2)	81 (2)
	FRPFRQ3	f>/f<,df/dt (3)	81 (3)
	FRPFRQ4	f>/f<,df/dt (4)	81 (4)
	FRPFRQ5	f>/f<,df/dt (5)	81 (5)
	FRPFRQ6	f>/f<,df/dt (6)	81 (6)
Three-phase thermal protection for feeders, cables and distribution transformers	T1PTTR1	3Ith>F (1)	49F (1)
Loss of phase (undercurrent)	PHPTUC1	3I< (1)	37 (1)
Circuit breaker failure protection	CCBRBRF1	3I>/I0>BF (1)	51BF/51NBF (1)
	CCBRBRF2	3I>/I0>BF (2)	51BF/51NBF (2)
	CCBRBRF3	3I>/I0>BF (3)	51BF/51NBF (3)
Three-phase inrush detector	INRPHAR1	3I2f> (1)	68 (1)
Master trip	TRPPTRC1	Master Trip (1)	94/86 (1)
	TRPPTRC2	Master Trip (2)	94/86 (2)
	TRPPTRC3	Master Trip (3)	94/86 (3)
	TRPPTRC4	Master Trip (4)	94/86 (4)
Arc protection	ARCSARC1	ARC (1)	50L/50NL (1)
	ARCSARC2	ARC (2)	50L/50NL (2)
	ARCSARC3	ARC (3)	50L/50NL (3)
High-impedance fault detection	PHIZ1	HIF (1)	HIZ (1)

Table 141. Functions included in the relay, continued

Function	IEC 61850	IEC 60617	ANSI
Load-shedding and restoration	LSHDPFRQ1	UFLS/R (1)	81LSH (1)
	LSHDPFRQ2	UFLS/R (2)	81LSH (2)
	LSHDPFRQ3	UFLS/R (3)	81LSH (3)
	LSHDPFRQ4	UFLS/R (4)	81LSH (4)
	LSHDPFRQ5	UFLS/R (5)	81LSH (5)
	LSHDPFRQ6	UFLS/R (6)	81LSH (6)
Multipurpose protection	MAPGAPC1	MAP (1)	MAP (1)
	MAPGAPC2	MAP (2)	MAP (2)
	MAPGAPC3	MAP (3)	MAP (3)
	MAPGAPC4	MAP (4)	MAP (4)
	MAPGAPC5	MAP (5)	MAP (5)
	MAPGAPC6	MAP (6)	MAP (6)
	MAPGAPC7	MAP (7)	MAP (7)
	MAPGAPC8	MAP (8)	MAP (8)
	MAPGAPC9	MAP (9)	MAP (9)
	MAPGAPC10	MAP (10)	MAP (10)
	MAPGAPC11	MAP (11)	MAP (11)
	MAPGAPC12	MAP (12)	MAP (12)
	MAPGAPC13	MAP (13)	MAP (13)
	MAPGAPC14	MAP (14)	MAP (14)
	MAPGAPC15	MAP (15)	MAP (15)
	MAPGAPC16	MAP (16)	MAP (16)
	MAPGAPC17	MAP (17)	MAP (17)
	MAPGAPC18	MAP (18)	MAP (18)
Automatic switch-onto-fault logic (SOF)	CVPSOF1	CVPSOF (1)	SOFT/21/50 (1)
Voltage vector shift protection	VVSPAM1	VS (1)	78V (1)
Directional reactive power undervoltage protection	DQPTUV1	Q> -> ,3U< (1)	32Q,27 (1)
	DQPTUV2	Q> -> ,3U< (2)	32Q,27 (2)
Underpower protection	DUPPDPR1	P< (1)	32U (1)
	DUPPDPR2	P< (2)	32U (2)
Reverse power/directional overpower protection	DOPPDPR1	P>/Q> (1)	32R/32O (1)
	DOPPDPR2	P>/Q> (2)	32R/32O (2)
Low-voltage ride-through protection	LVRTPTUV1	U<RT (1)	27RT (1)
	LVRTPTUV2	U<RT (2)	27RT (2)
	LVRTPTUV3	U<RT (3)	27RT (3)
High-impedance differential protection for phase A	HIAPDIF1	dHi_A> (1)	87A (1)
High-impedance differential protection for phase B	HIBPDIF1	dHi_B> (1)	87B (1)
High-impedance differential protection for phase C	HICPDIF1	dHi_C> (1)	87C (1)

Table 141. Functions included in the relay, continued

Function	IEC 61850	IEC 60617	ANSI
Circuit breaker uncorresponding position start-up	UPCALH1	CBUPS (1)	CBUPS (1)
	UPCALH2	CBUPS (2)	CBUPS (2)
	UPCALH3	CBUPS (3)	CBUPS (3)
Three-independent-phase non-directional overcurrent protection, low stage	PH3LPTOC1	3I _{3>} (1)	51P-1_3 (1)
	PH3LPTOC2	3I _{3>} (2)	51P-1_3 (2)
Three-independent-phase non-directional overcurrent protection, high stage	PH3HPTOC1	3I _{3>>} (1)	51P-2_3 (1)
	PH3HPTOC2	3I _{3>>} (2)	51P-2_3 (2)
Three-independent-phase non-directional overcurrent protection, instantaneous stage	PH3IPTOC1	3I _{3>>>} (1)	50P/51P_3 (1)
Directional three-independent-phase directional overcurrent protection, low stage	DPH3LPDOC1	3I _{3>} -> (1)	67-1_3 (1)
	DPH3LPDOC2	3I _{3>} -> (2)	67-1_3 (2)
Directional three-independent-phase directional overcurrent protection, high stage	DPH3HPDOC1	3I _{3>>} -> (1)	67-2_3 (1)
	DPH3HPDOC2	3I _{3>>} -> (2)	67-2_3 (2)
Three-phase overload protection for shunt capacitor banks	COLPTOC1	3I> 3I< (1)	51C/37 (1)
Current unbalance protection for shunt capacitor banks	CUBPTOC1	dI>C (1)	51NC-1 (1)
Shunt capacitor bank switching resonance protection, current based	SRCPTOC1	TD> (1)	55TD (1)
Control			
Circuit-breaker control	CBXCBR1	I <-> O CB (1)	I <-> O CB (1)
	CBXCBR2	I <-> O CB (2)	I <-> O CB (2)
	CBXCBR3	I <-> O CB (3)	I <-> O CB (3)
Disconnecter control	DCXSWI1	I <-> O DCC (1)	I <-> O DCC (1)
	DCXSWI2	I <-> O DCC (2)	I <-> O DCC (2)
	DCXSWI3	I <-> O DCC (3)	I <-> O DCC (3)
	DCXSWI4	I <-> O DCC (4)	I <-> O DCC (4)
Earthing switch control	ESXSWI1	I <-> O ESC (1)	I <-> O ESC (1)
	ESXSWI2	I <-> O ESC (2)	I <-> O ESC (2)
	ESXSWI3	I <-> O ESC (3)	I <-> O ESC (3)
Disconnecter position indication	DCSXSXI1	I <-> O DC (1)	I <-> O DC (1)
	DCSXSXI2	I <-> O DC (2)	I <-> O DC (2)
	DCSXSXI3	I <-> O DC (3)	I <-> O DC (3)
	DCSXSXI4	I <-> O DC (4)	I <-> O DC (4)
Earthing switch indication	ESSXSXI1	I <-> O ES (1)	I <-> O ES (1)
	ESSXSXI2	I <-> O ES (2)	I <-> O ES (2)
	ESSXSXI3	I <-> O ES (3)	I <-> O ES (3)
Autoreclosing	DARREC1	O -> I (1)	79 (1)
	DARREC2	O -> I (2)	79 (2)
Synchronism and energizing check	SECRSYN1	SYNC (1)	25 (1)

Table 141. Functions included in the relay, continued

Function	IEC 61850	IEC 60617	ANSI
Condition monitoring and supervision			
Circuit-breaker condition monitoring	SSCBR1	CBCM (1)	CBCM (1)
	SSCBR2	CBCM (2)	CBCM (2)
	SSCBR3	CBCM (3)	CBCM (3)
Trip circuit supervision	TCSSCBR1	TCS (1)	TCM (1)
	TCSSCBR2	TCS (2)	TCM (2)
Current circuit supervision	CCSPVC1	MCS 3I (1)	MCS 3I (1)
Current transformer supervision for high-impedance protection scheme for phase A	HZCCASPVC1	MCS I_A (1)	MCS I_A (1)
Current transformer supervision for high-impedance protection scheme for phase B	HZCCBSPVC1	MCS I_B (1)	MCS I_B (1)
Current transformer supervision for high-impedance protection scheme for phase C	HZCCCSPVC1	MCS I_C (1)	MCS I_C (1)
Fuse failure supervision	SEQSPVC1	FUSEF (1)	60 (1)
Runtime counter for machines and devices	MDSOPT1	OPTS (1)	OPTM (1)
	MDSOPT2	OPTS (2)	OPTM (2)
Measurement			
Three-phase current measurement	CMMXU1	3I (1)	3I (1)
Sequence current measurement	CSMSQI1	I1, I2, I0 (1)	I1, I2, I0 (1)
Residual current measurement	RESCMMXU1	Io (1)	In (1)
Three-phase voltage measurement	VMMXU1	3U (1)	3V (1)
Single-phase voltage measurement	VAMMXU2	U_A (2)	V_A (2)
Residual voltage measurement	RESVMMXU1	Uo (1)	Vn (1)
Sequence voltage measurement	VSMSQI1	U1, U2, U0 (1)	V1, V2, V0 (1)
Three-phase power and energy measurement	PEMMXU1	P, E (1)	P, E (1)
Load profile record	LDPRLRC1	LOADPROF (1)	LOADPROF (1)
Frequency measurement	FMMXU1	f (1)	f (1)
Fault location			
Fault locator	SCEFRFLO1	FLOC (1)	21FL (1)
Power quality			
Current total demand distortion	CMHAI1	PQM3I (1)	PQM3I (1)
Voltage total harmonic distortion	VMHAI1	PQM3U (1)	PQM3V (1)
Voltage variation	PHQVVR1	PQMU (1)	PQMV (1)
Voltage unbalance	VSQVUB1	PQUUB (1)	PQVUB (1)
Other			
Minimum pulse timer (2 pcs)	TPGAPC1	TP (1)	TP (1)
	TPGAPC2	TP (2)	TP (2)
	TPGAPC3	TP (3)	TP (3)
	TPGAPC4	TP (4)	TP (4)

Table 141. Functions included in the relay, continued

Function	IEC 61850	IEC 60617	ANSI
Minimum pulse timer (2 pcs, second resolution)	TPSGAPC1	TPS (1)	TPS (1)
	TPSGAPC2	TPS (2)	TPS (2)
Minimum pulse timer (2 pcs, minute resolution)	TPMGAPC1	TPM (1)	TPM (1)
	TPMGAPC2	TPM (2)	TPM (2)
Pulse timer (8 pcs)	PTGAPC1	PT (1)	PT (1)
	PTGAPC2	PT (2)	PT (2)
Time delay off (8 pcs)	TOFGAPC1	TOF (1)	TOF (1)
	TOFGAPC2	TOF (2)	TOF (2)
	TOFGAPC3	TOF (3)	TOF (3)
	TOFGAPC4	TOF (4)	TOF (4)
Time delay on (8 pcs)	TONGAPC1	TON (1)	TON (1)
	TONGAPC2	TON (2)	TON (2)
	TONGAPC3	TON (3)	TON (3)
	TONGAPC4	TON (4)	TON (4)
Set-reset (8 pcs)	SRGAPC1	SR (1)	SR (1)
	SRGAPC2	SR (2)	SR (2)
	SRGAPC3	SR (3)	SR (3)
	SRGAPC4	SR (4)	SR (4)
Move (8 pcs)	MVGAPC1	MV (1)	MV (1)
	MVGAPC2	MV (2)	MV (2)
	MVGAPC3	MV (3)	MV (3)
	MVGAPC4	MV (4)	MV (4)
Integer value move	MVI4GAPC1	MVI4 (1)	MVI4 (1)
	MVI4GAPC2	MVI4 (2)	MVI4 (2)
	MVI4GAPC3	MVI4 (3)	MVI4 (3)
	MVI4GAPC4	MVI4 (4)	MVI4 (4)
Analog value scaling	SCA4GAPC1	SCA4 (1)	SCA4 (1)
	SCA4GAPC2	SCA4 (2)	SCA4 (2)
	SCA4GAPC3	SCA4 (3)	SCA4 (3)
	SCA4GAPC4	SCA4 (4)	SCA4 (4)
Generic control point (16 pcs)	SPCGAPC1	SPC (1)	SPC (1)
	SPCGAPC2	SPC (2)	SPC (2)
	SPCGAPC3	SPC (3)	SPC (3)
Remote generic control points	SPCRGAPC1	SPCR (1)	SPCR (1)
Local generic control points	SPCLGAPC1	SPCL (1)	SPCL (1)

Table 141. Functions included in the relay, continued

Function	IEC 61850	IEC 60617	ANSI
Generic up-down counters	UDFCNT1	UDCNT (1)	UDCNT (1)
	UDFCNT2	UDCNT (2)	UDCNT (2)
	UDFCNT3	UDCNT (3)	UDCNT (3)
	UDFCNT4	UDCNT (4)	UDCNT (4)
	UDFCNT5	UDCNT (5)	UDCNT (5)
	UDFCNT6	UDCNT (6)	UDCNT (6)
	UDFCNT7	UDCNT (7)	UDCNT (7)
	UDFCNT8	UDCNT (8)	UDCNT (8)
	UDFCNT9	UDCNT (9)	UDCNT (9)
	UDFCNT10	UDCNT (10)	UDCNT (10)
	UDFCNT11	UDCNT (11)	UDCNT (11)
	UDFCNT12	UDCNT (12)	UDCNT (12)
Programmable buttons (16 buttons)	FKEYGGIO1	FKEY (1)	FKEY (1)
Logging functions			
Disturbance recorder	RDRE1	DR (1)	DFR (1)
Fault recorder	FLTRFRC1	FAULTREC (1)	FAULTREC (1)
Sequence event recorder	SER1	SER (1)	SER (1)

Feeder Protection and Control	1MRS757844 E
REF620	
Product version: 2.0 FP1	

33. Document revision history

Document revision/date	Product version	History
A/2013-05-07	2.0	First release
B/2013-07-01	2.0	Content updated
C/2014-07-01	2.0	Content updated
D/2014-09-11	2.0	Content updated
E/2015-12-11	2.0 FP1	Content updated to correspond to the product version

Contact us

ABB Oy

Medium Voltage Products, Distribution Automation

P.O. Box 699

FI-65101 VAASA, Finland

Phone +358 10 22 11

Fax +358 10 22 41094

www.abb.com/mediumvoltage

www.abb.com/substationautomation

ABB India Limited,

Distribution Automation

Maneja Works

Vadodara-390013, India

Phone +91 265 6724402

Fax +91 265 6724423

www.abb.com/mediumvoltage

www.abb.com/substationautomation

ABB

Nanjing SAC Power Grid Automation Co. Ltd.

NO.39 Shuige Road, Jiangning

Development Zone

211100 Nanjing, China

Phone +86 25 51183000

Fax +86 25 51183883

www.abb.com/substationautomation